

MV 301

Manual diaphragm valve

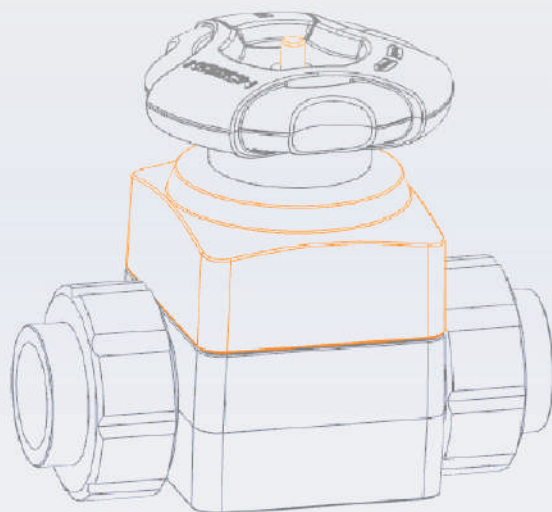

MV301 manual diaphragm valve is the new product with multifunctional adjustment module of ergonomics and with limit and lock functions as well. Superior flow channel and Diaphragm connection of the suspension structure, Make the performance of the product more superior.

Easy installation and maintenance

- * Easy to install with more snaps and threaded structures
- * All-plastic appearance is beautiful and corrosion resistant
- * Accurate screw fit clearance, smooth operation and maintenance-free
- * Same sizes and installation length as international brands products
- * Integrated visual position feedback and easy to observe
- * The adjustment module is Ergonomic
- * The handwheel has locking function every 22.5° precise adjustment and opening / closing management

High safety performance

- * Diaphragm compressor designs with limited position and torque overload protection
- * Diaphragm connection of the suspension structure to fully protect the diaphragm
- * The hand wheel adjusting module is provided with an integral locking switch, which can be padlocked

High Flexibility

- * True union connection, loose flange connection, butt-fusion connection without unions
- * DIN, JIS and ANSI standards are available
- * Diaphragms are available for EPDM, FPM and EPDM-PTFE
- * Bodies are available for PVC-U, PVC-C, PP-H and PVDF
- * Oil free valves are available for PP-H and PVDF valves

The best flow performance

- * Superior flow channel makes the linear characteristics of the fluid more precise and controllable
- * The smooth and excessive curved channel has smaller pressure loss, and brings double flow capacity compared with the traditional diaphragm valve
- * Suitable for liquids with small amounts of particles and solids

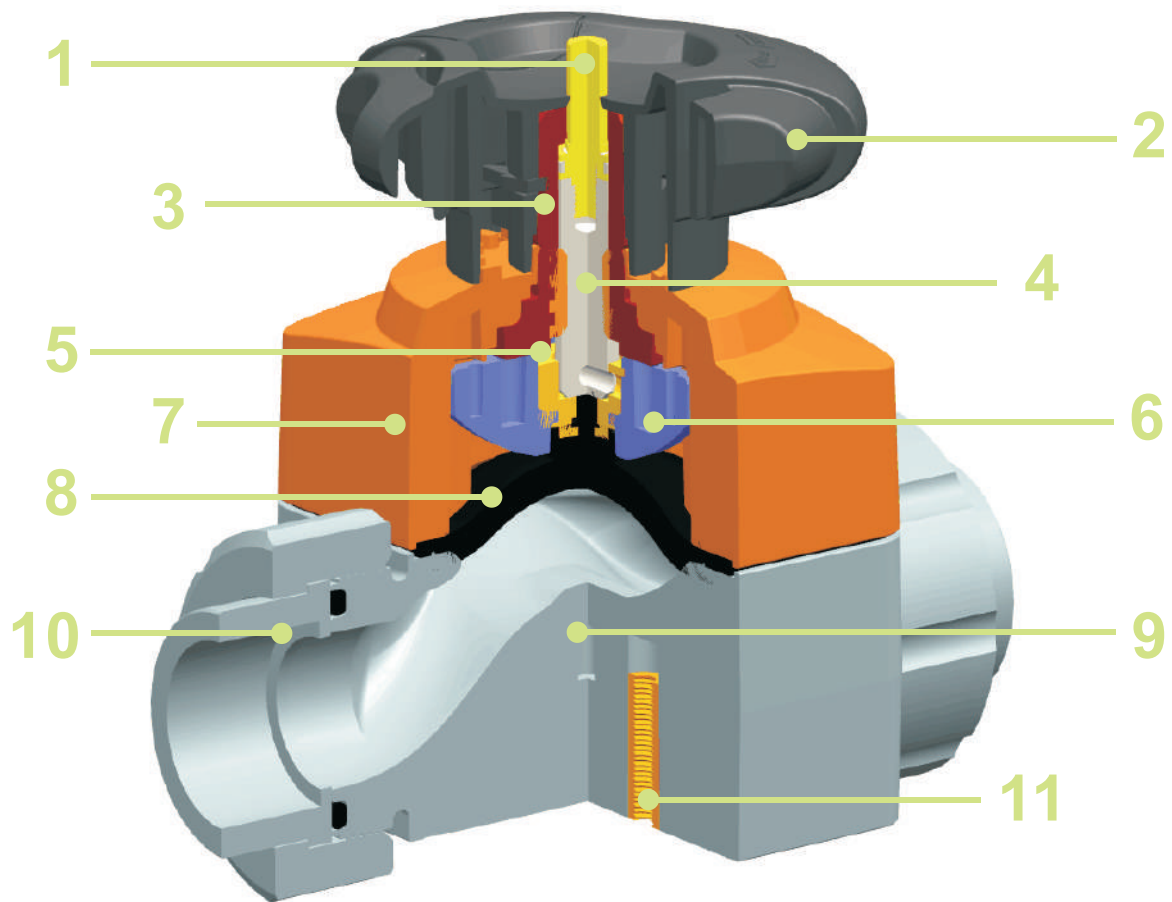

1 Indicator:
Bright and easy to see

2 Handwheel:
Adjustable limit
Including padlock function
module

3 Lead screw nut:
High strength
Friction resistant

4 Screw rod:
304F stainless steel
High Precision
Smooth operation

5 Coupling:
Screw rod connecting contactless
Independent suspension

6 Diaphragm compressor:
High strength, Not easy to deform
High temperature resistance

7 Seat cover:
Closed design
Suitable for rubber expansion

8 Diaphragm:
Embedded fiber vulcanization
Molded open state

9 Seat:
Duckbill runner has large
flow
Smooth curved path

10 Connection:
Different ways
Consistent with
international standards

11 Base:
Mounting nut included

+ Technical characteristics

Pressure temperature curve

All data based on water for consider -ring 25 years safe life time

Other liquids request to reduce the temperature and pressure accordingly

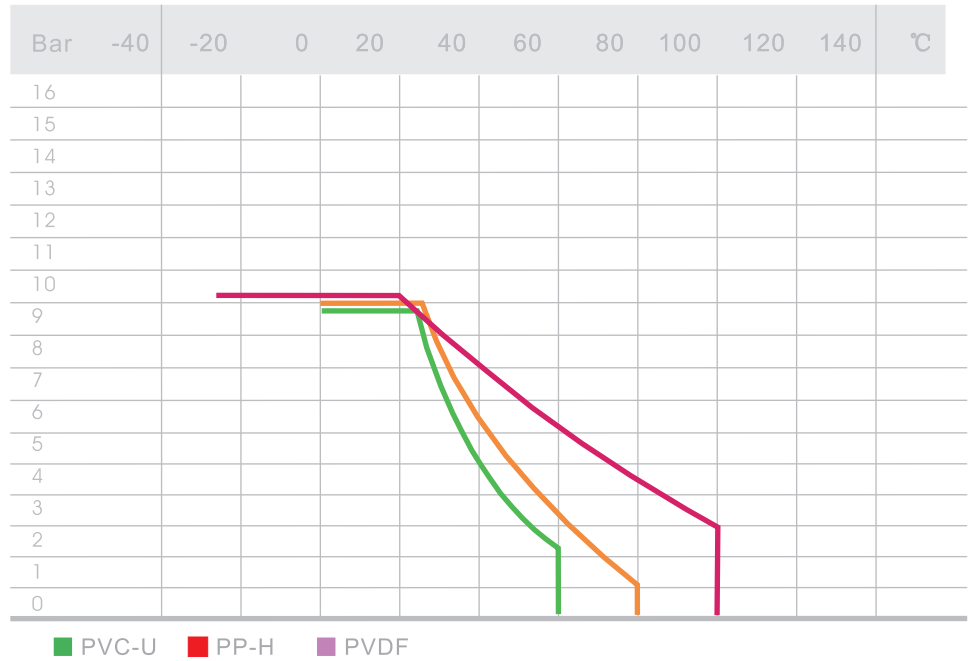

Flow capacity

All data are for 20°C water with 1 bar pressure difference

- $C_v = k_v \times 0,07$
- $F_v = k_v \times 0,0585$
- Kv (l/min)
- Cv (gal/min) US
- Fv (gal/min) GB

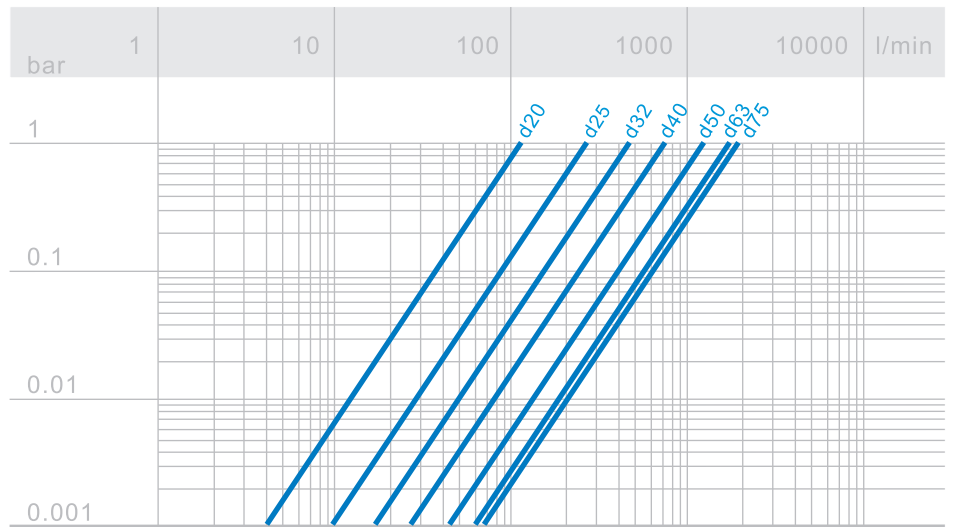

Line chart for relative flow rate

The linear coefficient of relative flow refers to the flow change as a function of valve opening stroke

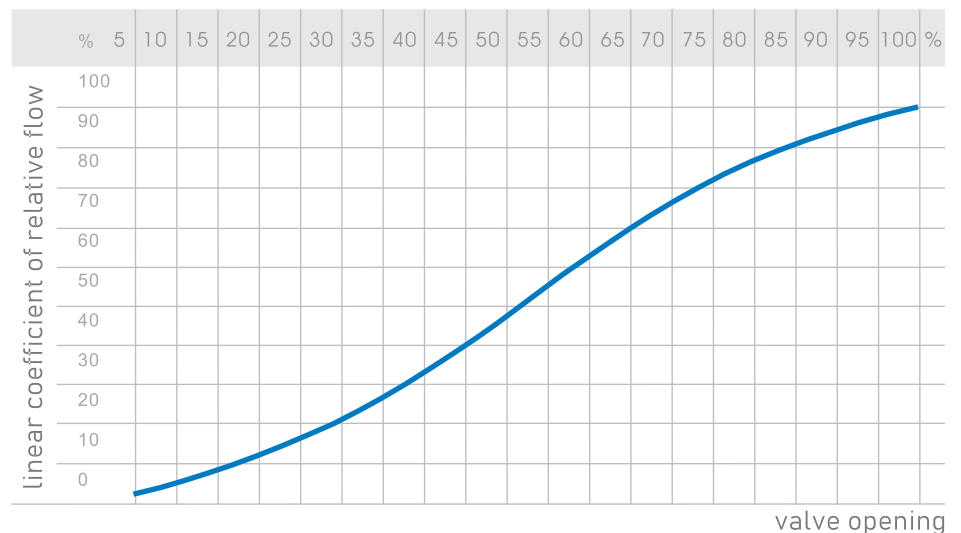

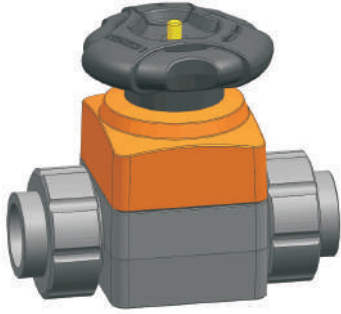

PVC-U Manual diaphragm valve
Union Socket-end
DIN

<i>d</i> (mm)	<i>DN</i> (mm)	<i>PN</i> (bar)	<i>EPDM(per)</i>	<i>FPM(70)</i>	<i>EPDM-PTFE</i>	<i>KG</i>
20	15	10	301.020.1020	301.040.1020	301.060.1020	0,3
25	20	10	301.020.1025	301.040.1025	301.060.1025	0,5
32	25	10	301.020.1032	301.040.1032	301.060.1032	1,0
40	32	10	301.020.1040	301.040.1040	301.060.1040	1,1
50	40	10	301.020.1050	301.040.1050	301.060.1050	2,3
63	50	10	301.020.1063	301.040.1063	301.060.1063	2,6

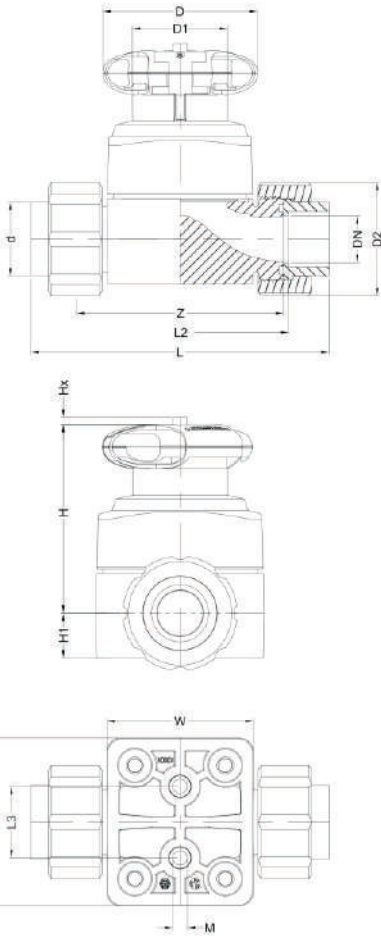

PVC-U Manual diaphragm valve
Union Socket-end
JIS

<i>d</i> (mm)	<i>DN</i> (mm)	<i>PN</i> (bar)	<i>EPDM(per)</i>	<i>FPM(70)</i>	<i>EPDM-PTFE</i>	<i>KG</i>
20	15	10	301.020.1220	301.040.1220	301.060.1220	0,3
25	20	10	301.020.1225	301.040.1225	301.060.1225	0,5
32	25	10	301.020.1232	301.040.1232	301.060.1232	1,0
40	32	10	301.020.1240	301.040.1240	301.060.1240	1,1
50	40	10	301.020.1250	301.040.1250	301.060.1250	2,3
63	50	10	301.020.1263	301.040.1263	301.060.1263	2,6

PVC-U Manual diaphragm valve
Union Socket-end
ANSI

<i>d</i> (mm)	<i>DN</i> (mm)	<i>PN</i> (bar)	<i>EPDM(per)</i>	<i>FPM(70)</i>	<i>EPDM-PTFE</i>	<i>KG</i>
1/2	15	10	301.020.1420	301.040.1420	301.060.1420	0,3
3/4	20	10	301.020.1425	301.040.1425	301.060.1425	0,5
1	25	10	301.020.1432	301.040.1432	301.060.1432	1,0
1-1/4	32	10	301.020.1440	301.040.1440	301.060.1440	1,1
1-1/2	40	10	301.020.1450	301.040.1450	301.060.1450	2,3
2	50	10	301.020.1463	301.040.1463	301.060.1463	2,6

Unit: mm

<i>d</i>	<i>DN</i>	<i>G</i>	<i>D</i>	<i>D1</i>	<i>D2</i>	<i>H</i>	<i>H1</i>	<i>L</i>	<i>L2</i>	<i>L3</i>	<i>M</i>	<i>Z</i>	<i>W</i>	<i>W1</i>	Lift = <i>Hx</i>
20	15	1	65	37	43	73	14	128	96	25	6	90	57	57	7
25	20	1-1/4	65	37	51	81	18	152	114	25	6	108	70	70	10
32	25	1-1/2	87	54	58	115	26	166	122	40	8	116	82	94	15
40	32	2	87	54	72	115	26	192	140	40	8	134	82	94	15
50	40	2-1/4	135	69	83	166	39	222	160	45	8	154	109	122	22
63	50	2-3/4	135	69	100	166	39	266	190	45	8	184	109	122	22



PVC-U Manual diaphragm valve

Flange

DIN

<i>d</i> (mm)	<i>DN</i> (mm)	<i>PN</i> (bar)	<i>EPDM(per)</i>	<i>FPM(70)</i>	<i>EPDM-PTFE</i>	<i>KG</i>
20	15	10	301.020.7020	301.040.7020	301.060.7020	0,8
25	20	10	301.020.7025	301.040.7025	301.060.7025	1,1
32	25	10	301.020.7032	301.040.7032	301.060.7032	1,8
40	32	10	301.020.7040	301.040.7040	301.060.7040	2,3
50	40	10	301.020.7050	301.040.7050	301.060.7050	3,7
63	50	10	301.020.7063	301.040.7063	301.060.7063	4,1
75	65	10	301.020.7075	301.040.7075	301.060.7075	5,4

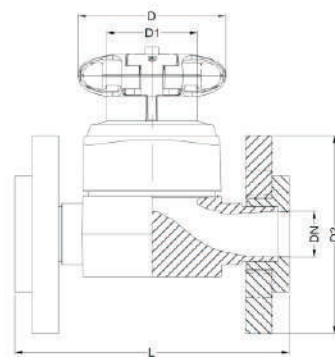

PVC-U Manual diaphragm valve

Flange

JIS

<i>d</i> (mm)	<i>DN</i> (mm)	<i>PN</i> (bar)	<i>EPDM(per)</i>	<i>FPM(70)</i>	<i>EPDM-PTFE</i>	<i>KG</i>
20	15	10	301.020.7220	301.040.7220	301.060.7220	0,8
25	20	10	301.020.7225	301.040.7225	301.060.7225	1,1
32	25	10	301.020.7232	301.040.7232	301.060.7232	1,8
40	32	10	301.020.7240	301.040.7240	301.060.7240	2,3
50	40	10	301.020.7250	301.040.7250	301.060.7250	3,7
63	50	10	301.020.7263	301.040.7263	301.060.7263	4,1
75	65	10	301.020.7275	301.040.7275	301.060.7275	5,4

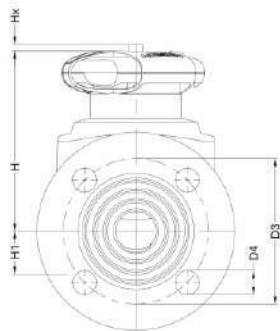

PVC-U Manual diaphragm valve

Flange

ANSI

<i>d</i> (mm)	<i>DN</i> (mm)	<i>PN</i> (bar)	<i>EPDM(per)</i>	<i>FPM(70)</i>	<i>EPDM-PTFE</i>	<i>KG</i>
1/2	15	10	301.020.7420	301.040.7420	301.060.7420	0,8
3/4	20	10	301.020.7425	301.040.7425	301.060.7425	1,1
1	25	10	301.020.7432	301.040.7432	301.060.7432	1,8
1-1/4	32	10	301.020.7440	301.040.7440	301.060.7440	2,3
1-1/2	40	10	301.020.7450	301.040.7450	301.060.7450	3,7
2	50	10	301.020.7463	301.040.7463	301.060.7463	4,1
2-1/2	65	10	301.020.7475	301.040.7475	301.060.7475	5,4

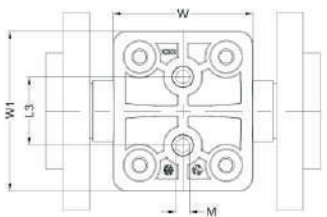

Unit: mm

<i>d</i>	<i>DN</i>	<i>D</i>	<i>D1</i>	<i>D2</i>	<i>D3</i> _{-DIN}	<i>D3</i> _{-JIS}	<i>D3</i> _{-ANSI}	<i>D4</i>	<i>H</i>	<i>H1</i>	<i>L</i>	<i>L3</i>	<i>M</i>	<i>W</i>	<i>W1</i>	<i>Lift = Hx</i>
20	15	65	37	95	65	70	60,45	14`16	81	18	145	25	6	70	70	10
25	20	65	37	105	75	75	69,85	14`16	81	18	150	25	6	70	70	10
32	25	87	54	115	85	90	79,25	14`19	115	26	170	40	8	82	94	15
40	32	87	54	140	100	100	88,90	16`19	115	26	180	40	8	82	94	15
50	40	135	69	150	110	105	98,55	16`19	166	39	210	45	8	109	122	23
63	50	135	69	165	125	120	120,65	18`20	166	39	230	45	8	109	122	23
75	65	135	69	185	145	139	139,70	18`20	173	46	245	45	8	109	122	24

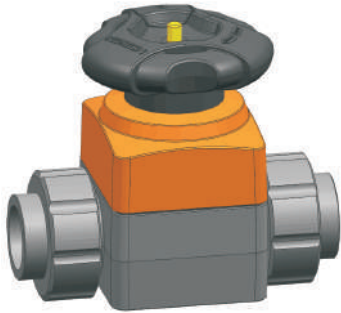

PVC-C Manual diaphragm valve
Union Socket-end
DIN

<i>d</i> (mm)	<i>DN</i> (mm)	<i>PN</i> (bar)	<i>EPDM(per)</i>	<i>FPM(70)</i>	<i>EPDM-PTFE</i>	<i>KG</i>
20	15	10	301.220.1020	301.240.1020	301.260.1020	0,3
25	20	10	301.220.1025	301.240.1025	301.260.1025	0,5
32	25	10	301.220.1032	301.240.1032	301.260.1032	1,0
40	32	10	301.220.1040	301.240.1040	301.260.1040	1,1
50	40	10	301.220.1050	301.240.1050	301.260.1050	2,3
63	50	10	301.220.1063	301.240.1063	301.260.1063	2,6

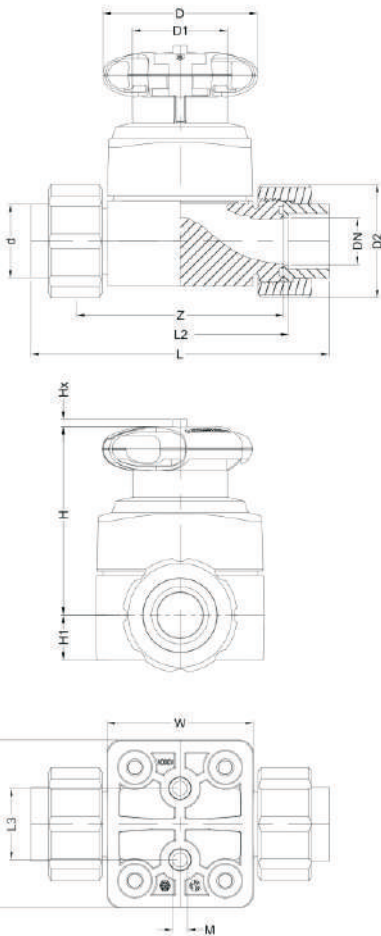

PVC-C Manual diaphragm valve
Union Socket-end
JIS

<i>d</i> (mm)	<i>DN</i> (mm)	<i>PN</i> (bar)	<i>EPDM(per)</i>	<i>FPM(70)</i>	<i>EPDM-PTFE</i>	<i>KG</i>
20	15	10	301.220.1220	301.240.1220	301.260.1220	0,3
25	20	10	301.220.1225	301.240.1225	301.260.1225	0,5
32	25	10	301.220.1232	301.240.1232	301.260.1232	1,0
40	32	10	301.220.1240	301.240.1240	301.260.1240	1,1
50	40	10	301.220.1250	301.240.1250	301.260.1250	2,3
63	50	10	301.220.1263	301.240.1263	301.260.1263	2,6

PVC-C Manual diaphragm valve
Union Socket-end
ANSI

<i>d</i> (mm)	<i>DN</i> (mm)	<i>PN</i> (bar)	<i>EPDM(per)</i>	<i>FPM(70)</i>	<i>EPDM-PTFE</i>	<i>KG</i>
1/2	15	10	301.220.1420	301.240.1420	301.260.1420	0,3
3/4	20	10	301.220.1425	301.240.1425	301.260.1425	0,5
1	25	10	301.220.1432	301.240.1432	301.260.1432	1,0
1-1/4	32	10	301.220.1440	301.240.1440	301.260.1440	1,1
1-1/2	40	10	301.220.1450	301.240.1450	301.260.1450	2,3
2	50	10	301.220.1463	301.240.1463	301.260.1463	2,6

Unit: mm

<i>d</i>	<i>DN</i>	<i>G</i>	<i>D</i>	<i>D1</i>	<i>D2</i>	<i>H</i>	<i>H1</i>	<i>L</i>	<i>L2</i>	<i>L3</i>	<i>M</i>	<i>Z</i>	<i>W</i>	<i>W1</i>	<i>Lift = Hx</i>
20	15	1	65	37	43	73	14	128	96	25	6	90	57	57	7
25	20	1-1/4	65	37	51	81	18	152	114	25	6	108	70	70	10
32	25	1-1/2	87	54	58	115	26	166	122	40	8	116	82	94	15
40	32	2	87	54	72	115	26	192	140	40	8	134	82	94	15
50	40	2-1/4	135	69	83	166	39	222	160	45	8	154	109	122	22
63	50	2-3/4	135	69	100	166	39	266	190	45	8	184	109	122	22



PVC-C Manual diaphragm valve

Flange

DIN

<i>d</i> (mm)	<i>DN</i> (mm)	<i>PN</i> (bar)	<i>EPDM(per)</i>	<i>FPM(70)</i>	<i>EPDM-PTFE</i>	<i>KG</i>
20	15	10	301.220.7020	301.240.7020	301.260.7020	0,8
25	20	10	301.220.7025	301.240.7025	301.260.7025	1,1
32	25	10	301.220.7032	301.240.7032	301.260.7032	1,8
40	32	10	301.220.7040	301.240.7040	301.260.7040	2,3
50	40	10	301.220.7050	301.240.7050	301.260.7050	3,7
63	50	10	301.220.7063	301.240.7063	301.260.7063	4,1
75	65	10	301.220.7075	301.240.7075	301.260.7075	5,4

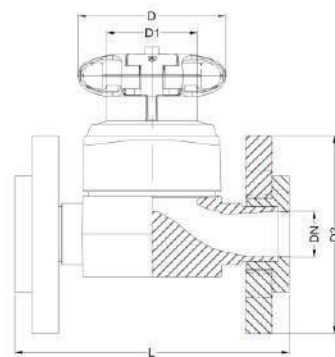

PVC-C Manual diaphragm valve

Flange

JIS

<i>d</i> (mm)	<i>DN</i> (mm)	<i>PN</i> (bar)	<i>EPDM(per)</i>	<i>FPM(70)</i>	<i>EPDM-PTFE</i>	<i>KG</i>
20	15	10	301.220.7220	301.240.7220	301.260.7220	0,8
25	20	10	301.220.7225	301.240.7225	301.260.7225	1,1
32	25	10	301.220.7232	301.240.7232	301.260.7232	1,8
40	32	10	301.220.7240	301.240.7240	301.260.7240	2,3
50	40	10	301.220.7250	301.240.7250	301.260.7250	3,7
63	50	10	301.220.7263	301.240.7263	301.260.7263	4,1
75	65	10	301.220.7275	301.240.7275	301.260.7275	5,4

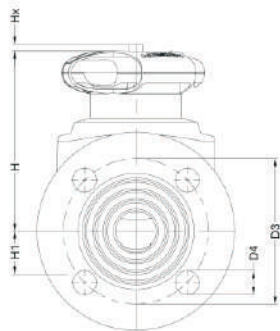

PVC-C Manual diaphragm valve

Flange

ANSI

<i>d</i> (mm)	<i>DN</i> (mm)	<i>PN</i> (bar)	<i>EPDM(per)</i>	<i>FPM(70)</i>	<i>EPDM-PTFE</i>	<i>KG</i>
1/2	15	10	301.220.7420	301.240.7420	301.260.7420	0,8
3/4	20	10	301.220.7425	301.240.7425	301.260.7425	1,1
1	25	10	301.220.7432	301.240.7432	301.260.7432	1,8
1-1/4	32	10	301.220.7440	301.240.7440	301.260.7440	2,3
1-1/2	40	10	301.220.7450	301.240.7450	301.260.7450	3,7
2	50	10	301.220.7463	301.240.7463	301.260.7463	4,1
2-1/2	65	10	301.220.7475	301.240.7075	301.260.7475	5,4

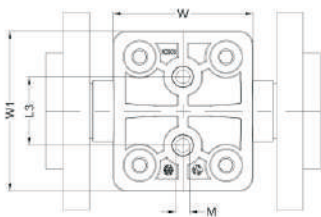

Unit: mm

<i>d</i>	<i>DN</i>	<i>D</i>	<i>D1</i>	<i>D2</i>	<i>D3</i> _{-DIN}	<i>D3</i> _{-JIS}	<i>D3</i> _{-ANSI}	<i>D4</i>	<i>H</i>	<i>H1</i>	<i>L</i>	<i>L3</i>	<i>M</i>	<i>W</i>	<i>W1</i>	<i>Lift = Hx</i>
20	15	65	37	95	65	70	60,45	14`16	81	18	145	25	6	70	70	10
25	20	65	37	105	75	75	69,85	14`16	81	18	150	25	6	70	70	10
32	25	87	54	115	85	90	79,25	14`19	115	26	170	40	8	82	94	15
40	32	87	54	140	100	100	88,90	16`19	115	26	180	40	8	82	94	15
50	40	135	69	150	110	105	98,55	16`19	166	39	210	45	8	109	122	23
63	50	135	69	165	125	120	120,65	18`20	166	39	230	45	8	109	122	23
75	65	135	69	185	145	139	139,70	18`20	173	46	245	45	8	109	122	24

PP-H Manual diaphragm valve
Union Socket-end
DIN

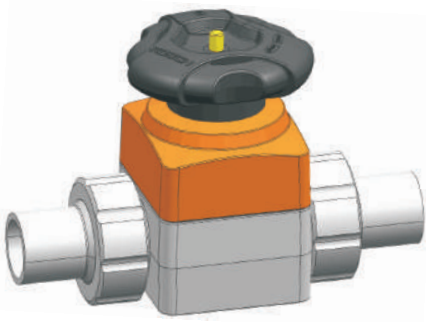

<i>d</i> (mm)	<i>DN</i> (mm)	<i>PN</i> (bar)	<i>EPDM(per)</i>	<i>FPM(70)</i>	<i>EPDM-PTFE</i>	<i>KG</i>
20	15	10	301.420.1020	301.440.1020	301.460.1020	0,3
25	20	10	301.420.1025	301.440.1025	301.460.1025	0,5
32	25	10	301.420.1032	301.440.1032	301.460.1032	0,9
40	32	10	301.420.1040	301.440.1040	301.460.1040	1,0
50	40	10	301.420.1050	301.440.1050	301.460.1050	2,0
63	50	10	301.420.1063	301.440.1063	301.460.1063	2,3

PP-H Manual diaphragm valve
Union Spigot Butt+IR
DIN

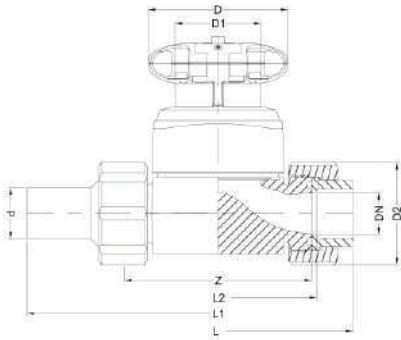

<i>d</i> (mm)	<i>DN</i> (mm)	<i>PN</i> (bar)	<i>EPDM(per)</i>	<i>FPM(70)</i>	<i>EPDM-PTFE</i>	<i>KG</i>
20	15	10	301.420.3020	301.440.3020	301.460.3020	0,3
25	20	10	301.420.3025	301.440.3025	301.460.3025	0,5
32	25	10	301.420.3032	301.440.3032	301.460.3032	0,9
40	32	10	301.420.3040	301.440.3040	301.460.3040	1,0
50	40	10	301.420.3050	301.440.3050	301.460.3050	2,0
63	50	10	301.420.3063	301.440.3063	301.460.3063	2,3

PP-H Manual diaphragm valve , Oil-free
Union Spigot Butt+IR
DIN

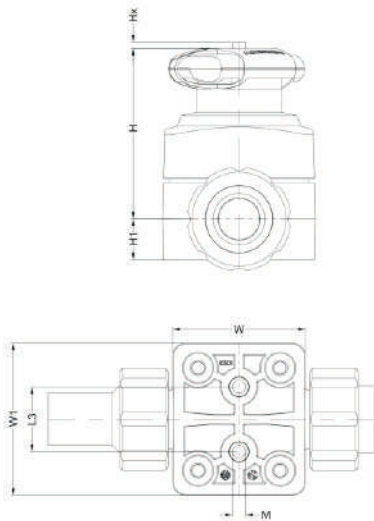

<i>d</i> (mm)	<i>DN</i> (mm)	<i>PN</i> (bar)	<i>EPDM-PTFE</i>	<i>KG</i>
20	15	10	301.460.3020.N	0,3
25	20	10	301.460.3025.N	0,5
32	25	10	301.460.3032.N	0,9
40	32	10	301.460.3040.N	1,0
50	40	10	301.460.3050.N	2,0
63	50	10	301.460.3063.N	2,3

Unit: mm

<i>d</i>	<i>DN</i>	<i>G</i>	<i>D</i>	<i>D1</i>	<i>D2</i>	<i>H</i>	<i>H1</i>	<i>L</i>	<i>L2</i>	<i>L3</i>	<i>M</i>	<i>Z</i>	<i>W</i>	<i>W1</i>	<i>Lift = Hx</i>
20	15	1	65	37	43	73	14	128	96	25	6	90	57	57	7
25	20	1-1/4	65	37	51	81	18	152	114	25	6	108	70	70	10
32	25	1-1/2	87	54	58	115	26	166	122	40	8	116	82	94	15
40	32	2	87	54	72	115	26	192	140	40	8	134	82	94	15
50	40	2-1/4	135	69	83	166	39	222	160	45	8	154	109	122	22
63	50	2-3/4	135	69	100	166	39	266	190	45	8	184	109	122	22



PP-H Manual diaphragm valve

Flange

DIN

<i>d</i> (mm)	<i>DN</i> (mm)	<i>PN</i> (bar)	<i>EPDM(per)</i>	<i>FPM(70)</i>	<i>EPDM-PTFE</i>	<i>KG</i>
20	15	10	301.420.7020	301.440.7020	301.460.7020	0,8
25	20	10	301.420.7025	301.440.7025	301.460.7025	1,0
32	25	10	301.420.7032	301.440.7032	301.460.7032	1,7
40	32	10	301.420.7040	301.440.7040	301.460.7040	2,2
50	40	10	301.420.7050	301.440.7050	301.460.7050	3,3
63	50	10	301.420.7063	301.440.7063	301.460.7063	3,6
75	65	10	301.420.7075	301.440.7075	301.460.7075	4,7

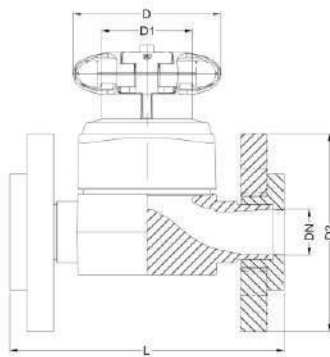

PP-H Manual diaphragm valve

Flange

JIS

<i>d</i> (mm)	<i>DN</i> (mm)	<i>PN</i> (bar)	<i>EPDM(per)</i>	<i>FPM(70)</i>	<i>EPDM-PTFE</i>	<i>KG</i>
20	15	10	301.420.7220	301.440.7220	301.460.7220	0,8
25	20	10	301.420.7225	301.440.7225	301.460.7225	1,0
32	25	10	301.420.7232	301.440.7232	301.460.7232	1,7
40	32	10	301.420.7240	301.440.7240	301.460.7240	2,2
50	40	10	301.420.7250	301.440.7250	301.460.7250	3,3
63	50	10	301.420.7263	301.440.7263	301.460.7263	3,6
75	65	10	301.420.7275	301.440.7275	301.460.7275	4,7

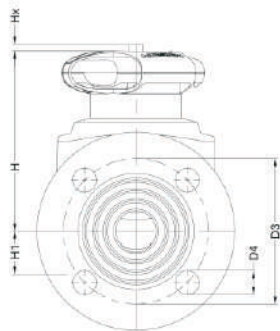

PP-H Manual diaphragm valve

Flange

ANSI

<i>d</i> (mm)	<i>DN</i> (mm)	<i>PN</i> (bar)	<i>EPDM(per)</i>	<i>FPM(70)</i>	<i>EPDM-PTFE</i>	<i>KG</i>
1/2	15	10	301.420.7420	301.440.7420	301.460.7420	0,8
3/4	20	10	301.420.7425	301.440.7425	301.460.7425	1,0
1	25	10	301.420.7432	301.440.7432	301.460.7432	1,7
1-1/4	32	10	301.420.7440	301.440.7440	301.460.7440	2,2
1-1/2	40	10	301.420.7450	301.440.7450	301.460.7450	3,3
2	50	10	301.420.7463	301.440.7463	301.460.7463	3,6
2-1/2	65	10	301.420.7475	301.440.7475	301.460.7475	4,7

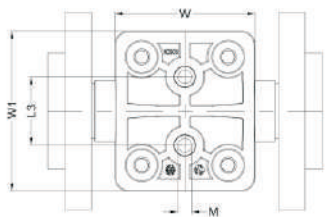

Unit: mm

<i>d</i>	<i>DN</i>	<i>D</i>	<i>D1</i>	<i>D2</i>	<i>D3_DIN</i>	<i>D3_JIS</i>	<i>D3_ANSI</i>	<i>D4</i>	<i>H</i>	<i>H1</i>	<i>L</i>	<i>L3</i>	<i>M</i>	<i>W</i>	<i>W1</i>	<i>Lift = Hx</i>
20	15	65	37	95	65	70	60,45	14`16	81	18	145	25	6	70	70	10
25	20	65	37	105	75	75	69,85	14`16	81	18	150	25	6	70	70	10
32	25	87	54	115	85	90	79,25	14`19	115	26	170	40	8	82	94	15
40	32	87	54	140	100	100	88,90	16`19	115	26	180	40	8	82	94	15
50	40	135	69	150	110	105	98,55	16`19	166	39	210	45	8	109	122	23
63	50	135	69	165	125	120	120,65	18`20	166	39	230	45	8	109	122	23
75	65	135	69	185	145	139	139,70	18`20	173	46	245	45	8	109	122	24

PP-Natural Manual diaphragm valve
 Union Socket-end
 DIN

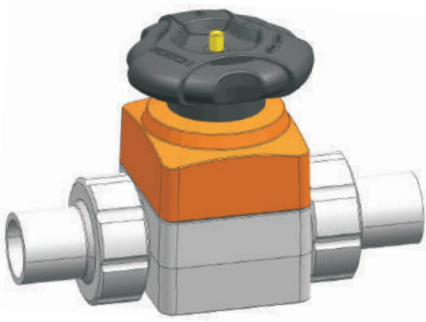

<i>d</i> (mm)	<i>DN</i> (mm)	<i>PN</i> (bar)	<i>EPDM(per)</i>	<i>EPDM-PTFE</i>	<i>KG</i>
20	15	10	301.520.1020	301.560.1020	0,3
25	20	10	301.520.1025	301.560.1025	0,5
32	25	10	301.520.1032	301.560.1032	0,9
40	32	10	301.520.1040	301.560.1040	1,0
50	40	10	301.520.1050	301.560.1050	2,0
63	50	10	301.520.1063	301.560.1063	2,3

PP-Natural Manual diaphragm valve
 Union Spigot Butt+IR
 DIN

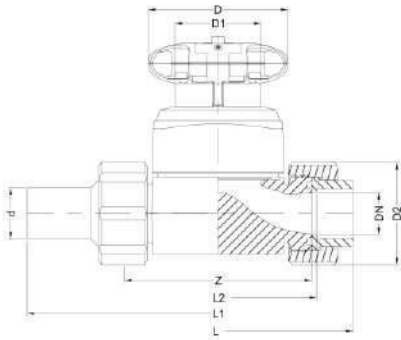

<i>d</i> (mm)	<i>DN</i> (mm)	<i>PN</i> (bar)	<i>EPDM(per)</i>	<i>EPDM-PTFE</i>	<i>KG</i>
20	15	10	301.520.3020	301.560.3020	0,3
25	20	10	301.520.3025	301.560.3025	0,5
32	25	10	301.520.3032	301.560.3032	0,9
40	32	10	301.520.3040	301.560.3040	1,0
50	40	10	301.520.3050	301.560.3050	2,0
63	50	10	301.520.3063	301.560.3063	2,3

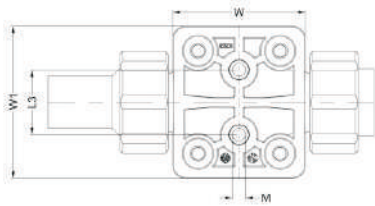
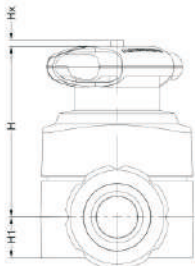

PP-Natural Manual diaphragm valve , Oil-free
 Union Spigot Butt+IR
 DIN

<i>d</i> (mm)	<i>DN</i> (mm)	<i>PN</i> (bar)	<i>EPDM-PTFE</i>	<i>KG</i>
20	15	10	301.560.3020.N	0,3
25	20	10	301.560.3025.N	0,5
32	25	10	301.560.3032.N	0,9
40	32	10	301.560.3040.N	1,0
50	40	10	301.560.3050.N	2,0
63	50	10	301.560.3063.N	2,3

Unit: mm

<i>d</i>	<i>DN</i>	<i>G</i>	<i>D</i>	<i>D1</i>	<i>D2</i>	<i>H</i>	<i>H1</i>	<i>L</i>	<i>L2</i>	<i>L3</i>	<i>M</i>	<i>Z</i>	<i>W</i>	<i>W1</i>	<i>Lift = Hx</i>
20	15	1	65	37	43	73	14	128	96	25	6	90	57	57	7
25	20	1-1/4	65	37	51	81	18	152	114	25	6	108	70	70	10
32	25	1-1/2	87	54	58	115	26	166	122	40	8	116	82	94	15
40	32	2	87	54	72	115	26	192	140	40	8	134	82	94	15
50	40	2-1/4	135	69	83	166	39	222	160	45	8	154	109	122	22
63	50	2-3/4	135	69	100	166	39	266	190	45	8	184	109	122	22

PVDF Manual diaphragm valve
 Union Socket-end
 DIN

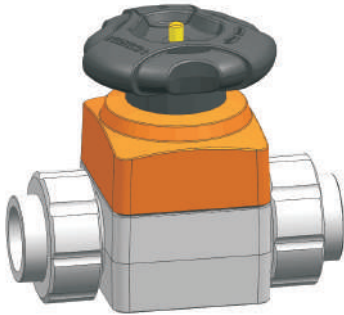

<i>d</i> (mm)	<i>DN</i> (mm)	<i>PN</i> (bar)	<i>FPM(70)</i>	<i>EPDM-PTFE</i>	<i>KG</i>
20	15	10	301.640.1020	301.660.1020	0,4
25	20	10	301.640.1025	301.660.1025	0,6
32	25	10	301.640.1032	301.660.1032	1,2
40	32	10	301.640.1040	301.660.1040	1,4
50	40	10	301.640.1050	301.660.1050	2,7
63	50	10	301.640.1063	301.660.1063	3,0

PVDF Manual diaphragm valve
 Union Spigot Butt+IR
 DIN

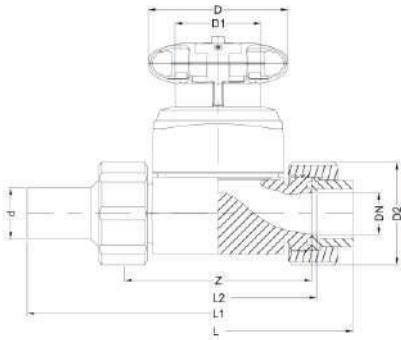

<i>d</i> (mm)	<i>DN</i> (mm)	<i>PN</i> (bar)	<i>FPM(70)</i>	<i>EPDM-PTFE</i>	<i>KG</i>
20	15	10	301.640.3020	301.660.3020	0,4
25	20	10	301.640.3025	301.660.3025	0,6
32	25	10	301.640.3032	301.660.3032	1,2
40	32	10	301.640.3040	301.660.3040	1,4
50	40	10	301.640.3050	301.660.3050	2,7
63	50	10	301.640.3063	301.660.3063	3,0

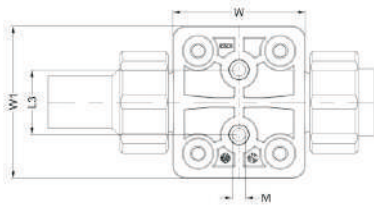
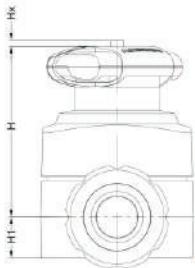

PVDF Manual diaphragm valve , Oil-free
 Union Spigot Butt+IR
 DIN

<i>d</i> (mm)	<i>DN</i> (mm)	<i>PN</i> (bar)	<i>EPDM-PTFE</i>	<i>KG</i>
20	15	10	301.660.3020.N	0,4
25	20	10	301.660.3025.N	0,6
32	25	10	301.660.3032.N	1,2
40	32	10	301.660.3040.N	1,4
50	40	10	301.660.3050.N	2,7
63	50	10	301.660.3063.N	3,0

Unit: mm

<i>d</i>	<i>DN</i>	<i>G</i>	<i>D</i>	<i>D1</i>	<i>D2</i>	<i>H</i>	<i>H1</i>	<i>L</i>	<i>L2</i>	<i>L3</i>	<i>M</i>	<i>Z</i>	<i>W</i>	<i>W1</i>	<i>Lift = Hx</i>
20	15	1	65	37	43	73	14	128	96	25	6	90	57	57	7
25	20	1-1/4	65	37	51	81	18	152	114	25	6	108	70	70	10
32	25	1-1/2	87	54	58	115	26	166	122	40	8	116	82	94	15
40	32	2	87	54	72	115	26	192	140	40	8	134	82	94	15
50	40	2-1/4	135	69	83	166	39	222	160	45	8	154	109	122	22
63	50	2-3/4	135	69	100	166	39	266	190	45	8	184	109	122	22

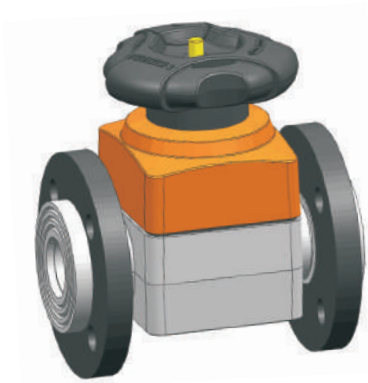

PVDF Manual diaphragm valve

Flange

DIN

<i>d</i> (mm)	<i>DN</i> (mm)	<i>PN</i> (bar)	<i>FPM(70)</i>	<i>EPDM-PTFE</i>	<i>KG</i>
20	15	10	301.640.7020	301.660.7020	0,8
25	20	10	301.640.7025	301.660.7025	1,2
32	25	10	301.640.7032	301.660.7032	1,9
40	32	10	301.640.7040	301.660.7040	2,5
50	40	10	301.640.7050	301.660.7050	3,9
63	50	10	301.640.7063	301.660.7063	4,4
75	65	10	301.640.7075	301.660.7075	5,7

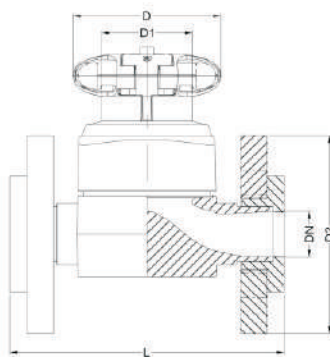

PVDF Manual diaphragm valve

Flange

JIS

<i>d</i> (mm)	<i>DN</i> (mm)	<i>PN</i> (bar)	<i>FPM(70)</i>	<i>EPDM-PTFE</i>	<i>KG</i>
20	15	10	301.640.7220	301.660.7220	0,8
25	20	10	301.640.7225	301.660.7225	1,2
32	25	10	301.640.7232	301.660.7232	1,9
40	32	10	301.640.7240	301.660.7240	2,5
50	40	10	301.640.7250	301.660.7250	3,9
63	50	10	301.640.7263	301.660.7263	4,4
75	65	10	301.640.7275	301.660.7275	5,7

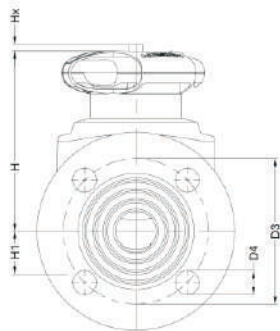

PVDF Manual diaphragm valve

Flange

ANSI

<i>d</i> (mm)	<i>DN</i> (mm)	<i>PN</i> (bar)	<i>FPM(70)</i>	<i>EPDM-PTFE</i>	<i>KG</i>
1/2	15	10	301.640.7420	301.660.7420	0,8
3/4	20	10	301.640.7425	301.660.7425	1,2
1	25	10	301.640.7432	301.660.7432	1,9
1-1/4	32	10	301.640.7440	301.660.7440	2,5
1-1/2	40	10	301.640.7450	301.660.7450	3,9
2	50	10	301.640.7463	301.660.7463	4,4
2-1/2	65	10	301.640.7475	301.660.7475	5,7

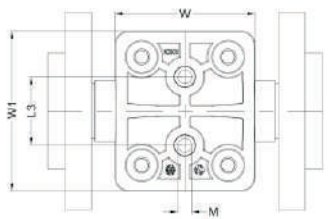

Unit: mm

<i>d</i>	<i>DN</i>	<i>D</i>	<i>D1</i>	<i>D2</i>	<i>D3</i> _{-DIN}	<i>D3</i> _{-JIS}	<i>D3</i> _{-ANSI}	<i>D4</i>	<i>H</i>	<i>H1</i>	<i>L</i>	<i>L3</i>	<i>M</i>	<i>W</i>	<i>W1</i>	<i>Lift = Hx</i>
20	15	65	37	95	65	70	60,45	14`16	81	18	145	25	6	70	70	10
25	20	65	37	105	75	75	69,85	14`16	81	18	150	25	6	70	70	10
32	25	87	54	115	85	90	79,25	14`19	115	26	170	40	8	82	94	15
40	32	87	54	140	100	100	88,90	16`19	115	26	180	40	8	82	94	15
50	40	135	69	150	110	105	98,55	16`19	166	39	210	45	8	109	122	23
63	50	135	69	165	125	120	120,65	18`20	166	39	230	45	8	109	122	23
75	65	135	69	185	145	139	139,70	18`20	173	46	245	45	8	109	122	24

**ontact**
customer center
www.koscn.cn



KOSCN