

Instruction Manual

Manual Diaphragm Valve MV 301

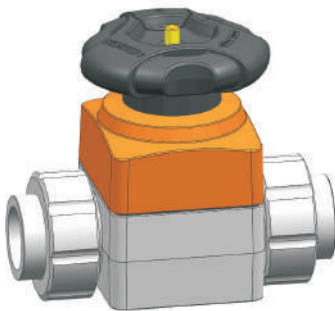

Content

1	Intended use	02
2	Requirements for user and operator responsibility	02
3	Safety and responsibility	03
4	Transport and storage	03
5	Product description	04
6	Installation	05
7	Commissioning	07
8	Normal operation and maintenance	08
9	Accessories and spare parts	09
10	Disposal	09

Original instruction manual

Observe instruction manual

The instruction manual is part of the product and an important element within the safety concept.

- ▶ Read and observe instruction manual.
- ▶ Always have instruction manual available at the product.
- ▶ Pass on instruction manual to all subsequent users of the product.

1 Intended use

The diaphragm valves type 301 are intended exclusively for shutting off and conveying media in the allowable pressure and temperature range or for controlling flow in piping systems into which they have been installed. The valve is intended to be used within the chemical resistance of the valve and all components involved.

2 Requirements for user and operator responsibility

- ▶ The diaphragm valve must only be used according to the specifications for which it has been intended
- ▶ Piping system must be installed by professionals and its functionality is checked regularly
- ▶ Installation, operation, service and repairs must only be carried out by qualified personnel
- ▶ Users and operators must be instructed on a regular basis in all aspects of work safety and environmental protection especially those pertaining to pressure-bearing piping systems
- ▶ The users and operators must be familiar with the operating instructions and must adhere to the information contained therein

3 Safety and responsibility

The valve is intended to be used in order to chapter 1 "Intended use".

- ▶ Only operate the diaphragm Valve in faultless and correct conditions.
- ▶ The product and accessories are installed only by persons who have the required training, knowledge or experience.
- ▶ Make sure that the piping system is correctly laid and that it is regularly inspected.
- ▶ Train the Personnel regularly on all matters related to the local regulations on occupational health and safety and environmental protection, especially regarding pressurized pipes in case.
- ▶ Respect the operating instructions for the valve and all other additional modules.

4 Transport and storage

The product has to be treated, transported and stocked carefully.

Follow the instructions below:

- ▶ Protect the product against external force during transport (impact, stroke, vibrations).
- ▶ Transport and/or store product in its original packaging.
- ▶ Make sure that the product cannot be damaged neither by mechanical nor by chemical impacts.
- ▶ Check the product prior to assembly on transport damages.
- ▶ Protect the product from dust, dirt, moisture as well as heat and ultraviolet radiation.
- ▶ Especially the connections have to be protected against mechanical and chemical impacts.
- ▶ The diaphragm valve should be stored in opened position.

5 Product description

5.1 Design

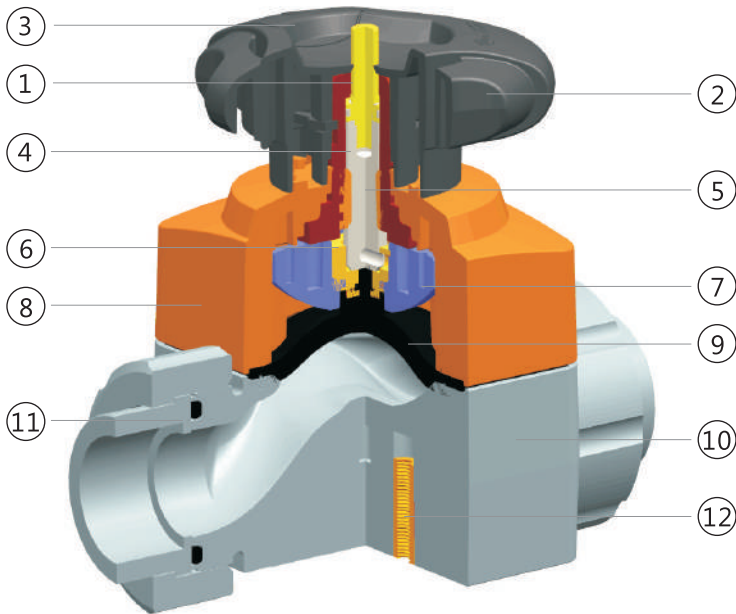

Pos.	Name	Pos.	Name
1	Position Indicator	7	Compressor
2	Hand wheel	8	The cover
3	Locking device	9	Diaphragm
4	Screw the nut	10	Valve body
5	Screw	11	Union
6	Coupling	12	Install the nut

5.2 Type plate

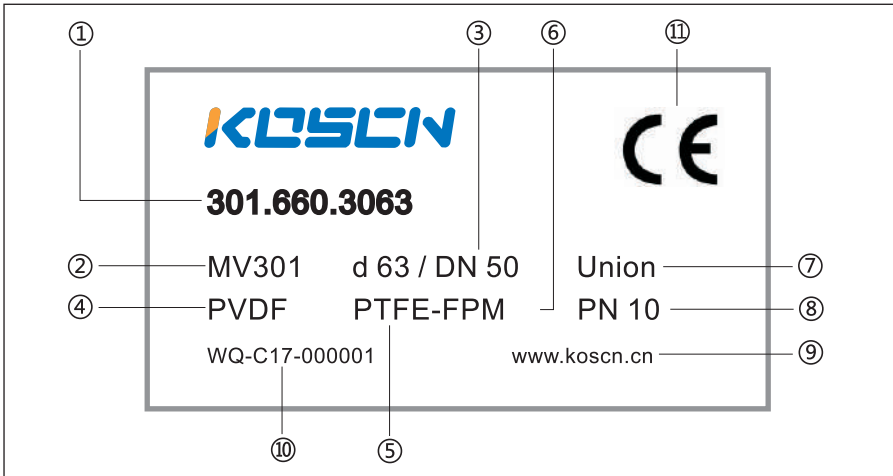

Pos.	Name	Pos.	Name
1	Code number	6	O-ring material
2	Type	7	Connection
3	Dimension	8	Pressure Rating
4	Valve body material	9	Web
5	Diaphragm material	10	Serial number
		11	CE-Marking

6 Installation

6.1 General information

Diaphragm valve installation in a piping system is subject to the same regulations as other connecting elements of pipes, fittings and related piping system components. Further chapters in the Planning Fundamentals give you additional information regarding installation and jointing methods.

6.2 Installation process

Before installation, please check the diaphragm valve accordingly to the following points:

- ▶ Inspect the diaphragm valve for transport damages. Damaged valves must not be installed
- ▶ Only use diaphragm valves where the valve and the diaphragm correspond specifically to the materials, pressure rating, type of connection and dimensions for the particular application
- ▶ Carry out function test: open and close the diaphragm valve manually
- ▶ Diaphragms and other sealing elements should be checked before mounting to make sure there are no damages from aging. Aged parts which exhibit hardening or fissures must not be installed
- ▶ You must not install valves which do not function properly
- ▶ After installation another function test is to be carried out

True Union Design

All materials with valve body type 301

1. Loosen the union nut and push them toward the designated piping end
2. Depending on the type of piping end, connecting parts are cemented, screwed or welded
3. Diaphragm valve is then positioned between the connecting parts
4. Manually tightened the union nuts

Cement connections

UPVC, CPVC

Only identical materials may be jointed together. Pipe sections with solvent cement connections should be rinsed unpressurized with water after the drying time

Fusion connections

PP-H, PVDF

Only identical materials may be jointed together

Flange connections

All materials with valve body type 301

1. Ensure the level between flanges
2. Use suitable spacers
3. For bolt size, please refer to the selection data sheet

6.3 Safety messages for the installation

Fixation of the diaphragm valve. Due to temperature changes, longitudinal or lateral forces may occur if thermal expansion is constrained.

- ▶ Absorb forces via respective fixed points in front or after the valve
- ▶ Operation of a valve causes reactive forces which could damage the valve
- ▶ Mount the diaphragm valve as a fixed point with the designated fastener or reinforce the piping directly before and after the diaphragm valve with suitable supports. Superimposed loadings could damage the diaphragm valve
- ▶ Diaphragm valve and piping must be aligned

7 Commissioning

Diaphragm valve pressure testing is subject to the same regulations as the piping system; however, the test pressure may not exceed the PN of the diaphragm valve.

NOTICE

1. Operate the diaphragm valve

Damage of diaphragm valve is possible if actuating torque is too high.

- ▶ Operate the valve with normal manual hand power
- ▶ Use no additional tools which increase actuating torque

2. Control operations

Due to cavitation the diaphragm valve could be damaged.

- ▶ Use valve only at optimal control operation conditions

Information

Slight hysteresis occurs in the steady state characteristics when the direction of actuation is changed.

Procedure commissioning

- ▶ Check that all valves are in the required open or closed position
- ▶ Fill the piping system and deaerate completely
- ▶ The component with the lowest PN determines the maximum allowable test pressure in the piping section
- ▶ The valves and connections should be checked for a tight seal during the pressure test

8 Normal operation and maintenance

The connection between the bonnet and valve body should be checked for tightness at regular intervals.

Check functionality regularly

We recommend checking the functionality of diaphragm valves which are kept permanently opened or closed.

This can be done by unseating the diaphragm manually 1 to 2 times a year.

Safety messages for normal operations and maintenance

Diaphragm valve used as end valve

Medium can exit uncontrollably, if piping system is opened under pressure. Death or serious injury could occur due to contact with the medium.

- ▶ The end valve may only be opened when the medium can be caught or carried off safely and splashing is prevented by taking appropriate measures

Dismounting diaphragm valve or opening the housing

The medium may exit uncontrollably or flow out from the pipe or valve, whether under pressure or not. The valve or pipe may contain residue or remnants of aggressive, hazardous, flammable or explosive medium. Death or serious injury could occur due to contact with the medium.

- ▶ Release all pressure from the piping system
- ▶ Empty the piping system completely
- ▶ Rinse the system, if aggressive, hazardous, flammable or explosive media are involved
- ▶ Empty the diaphragm valve completely when it has been dismantled. In order to do so, let the valve drain completely

8.1 Hand wheel locking device

Hand wheel in opened (left) and locked position (right)

Locking: the locking buckle slides out

Freedom: push the lock



9 Accessories and spare parts

Risk of injury and missing product quality through use of spare parts which have not been provided by KOSCN Industry!

If no spare part code is specified, order as follows:

- ▶ Read code number and serial number of the diaphragm valve on the type.
- ▶ Position numbers and descriptions can be read out from the spare parts list.
- ▶ Send your order with these information to your representative of KOSCN industry.

10 Disposal

- ▶ Before disposing of the product separate the different materials, by recyclables, normal waste and special waste.
- ▶ Comply with local legal regulations and provisions when recycling or disposing of the product, the individual components and the packaging.
- ▶ Comply with national regulations, standards and directives.

Parts of the product may be contaminated with media that are harmful to health and the environment, so it is not enough just to clean them!

These media represent a risk of physical injury or damage to the environment.

Before disposing of the product:

- ▶ Collect any spilled media and dispose of according to the local regulations. Refer to the safety data sheet.
- ▶ Neutralise any media residues remaining in the product.
- ▶ Separate the materials (plastics, metals etc.) and dispose of them according to local regulations.



A product marked with this symbol must be taken to a separate collection point for electrical and electronic devices.

