

MV 301

手動隔膜閥

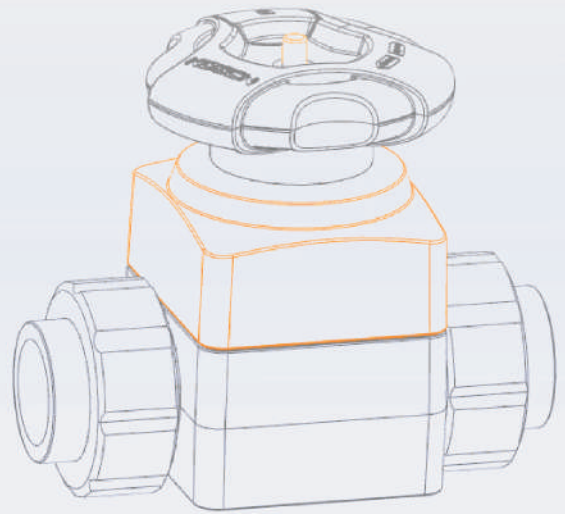

KOSCN Control Valves MV301 手動隔膜閥為最新開發的產品，多功能調節模塊融合人體工程學理念，並實現限位的鎖止功能。隔膜聯軸避空懸掛的新型結構和平滑流道對通量的保證，使之具有優越的性能表現。

方便操作和維護

- * 採用較多的卡扣和螺紋連接，易拆裝
- * 全塑的外觀結構，美觀且耐腐蝕
- * 精準的螺桿配合間細，操作順滑免維護
- * 所有連接形式和國際市場閥門保持一致安裝長度
- * 集成可視位置反饋，且易於觀察
- * 調節模塊符合人體工程學
- * 手輪每 22.5° 有鎖止槽，精準開閉度管理

高安全性能

- * 膜片止擋限位設計，扭矩過載保護
- * 懸掛式避空的隔膜聯軸機構，對膜片充分保護
- * 手輪調節模塊帶一體式鎖止開關，可掛鎖

高靈活性

- * 連接形式有由令、承插、對焊、法蘭
- * 接口標準有公制、日標、美標
- * 膜片 EPDM、FPM、EPDM-PTFE
- * 閥體 PVC-U、PVC-C、PP-H、PP-N、PE、PVDF
- * 部份產品有禁油選擇

最佳流通性能

- * 良好的線性流體特性可以實現調節功能
- * 平滑過度的鴨嘴流道，實現比傳統隔膜閥的雙倍流通能力
- * 適合含有少量顆粒和固體的介質

應用

- * 垃圾滲透液
- * 光伏
- * 集成電路板
- * 電鍍
- * 玻璃面板
- * 電子半導體
- * 電力
- * 鋼鐵冶金
- * 石油化工
- * 造紙
- * 氯鹼
- * 生物製藥
- * 食品飲料

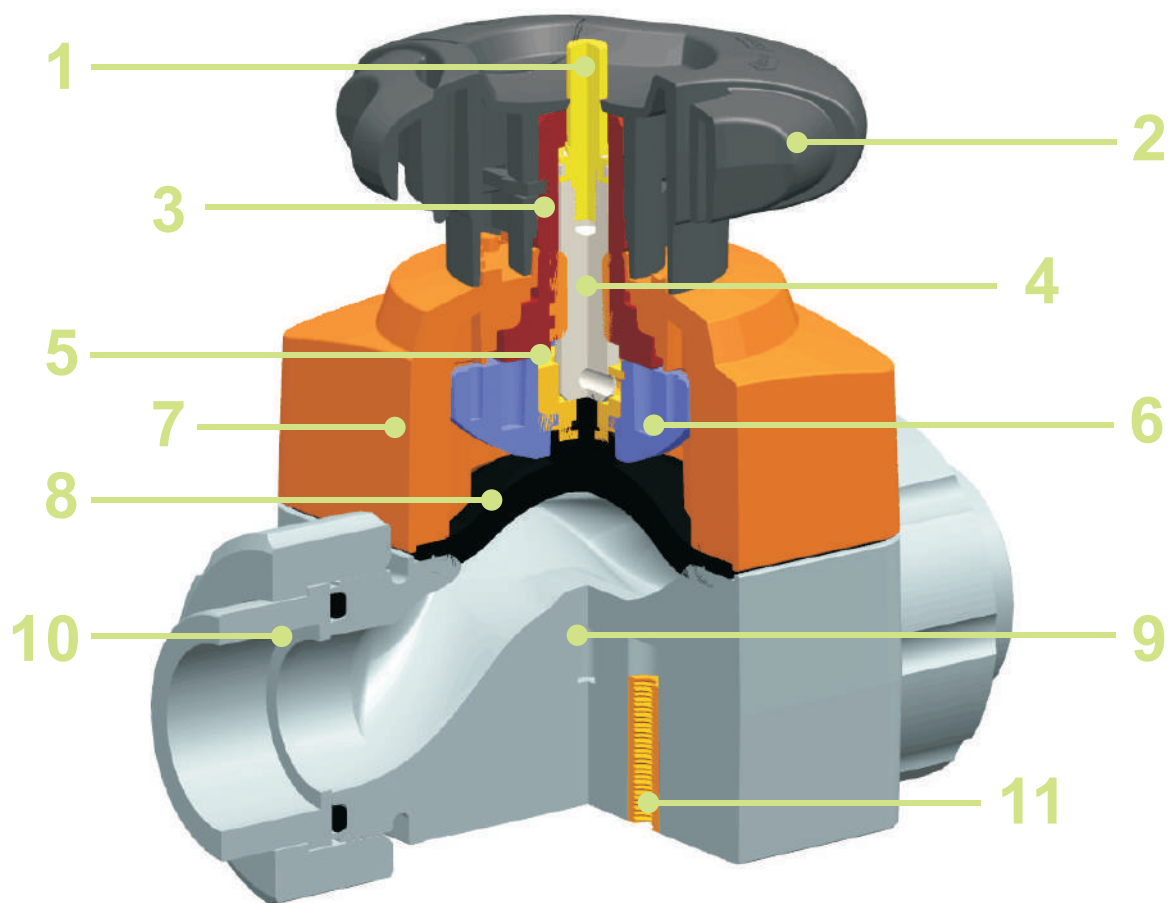

1 指示桿：
明亮易觀察

2 手輪：
可調節限位
含掛鎖功能模塊

3 絲槓螺母：
高強度耐摩擦
耐高溫不易變形

4 絲桿：
高精度
操控順滑

5 聯軸器：
避空連接絲桿
隔膜獨立懸掛

6 隔膜壓塊：
高強度不易變形
耐高溫

7 閥座蓋：
封閉設計
適應橡膠膨脹

8 隔膜：
內嵌纖維硫化
模制開狀態

9 閥座：
鴨嘴流道通量大
平滑曲徑

10 接口：
多樣化
國際市場一致

11 底座：
含安裝螺母

壓力 溫度曲線

數據基於清水類介質
及25年的安全壽命；

其他介質的應用
必須降低溫度和壓力

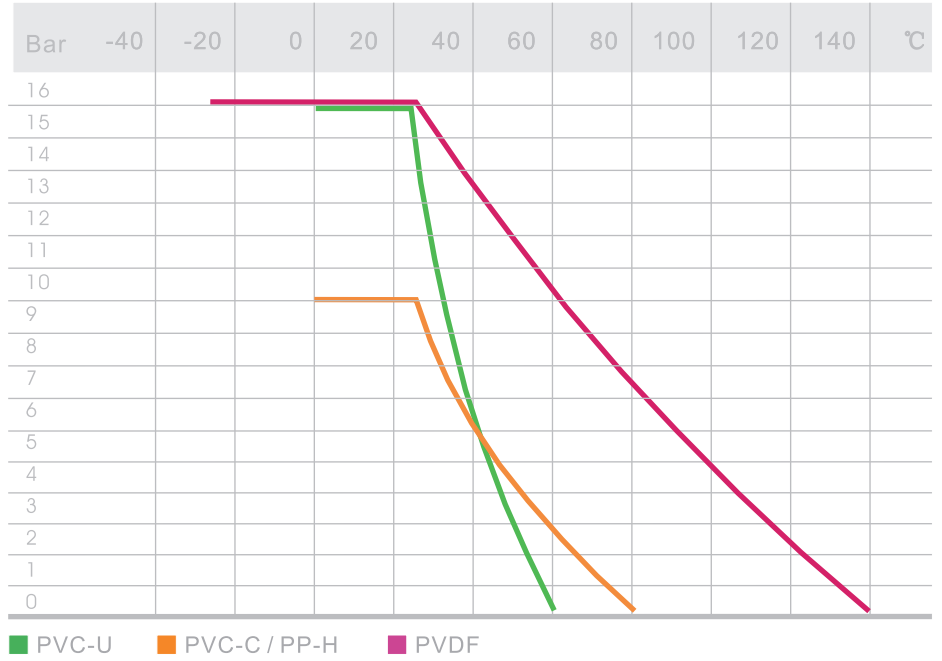

流通能力

基於20°C 清水類介質
及1bar 壓差時數據；

$$C_v = k_v \times 0,07$$

$$F_v = k_v \times 0,0585$$

$$K_v \text{ (l/min)}$$

$$C_v \text{ (gal/min) US}$$

$$F_v \text{ (gal/min) GB}$$

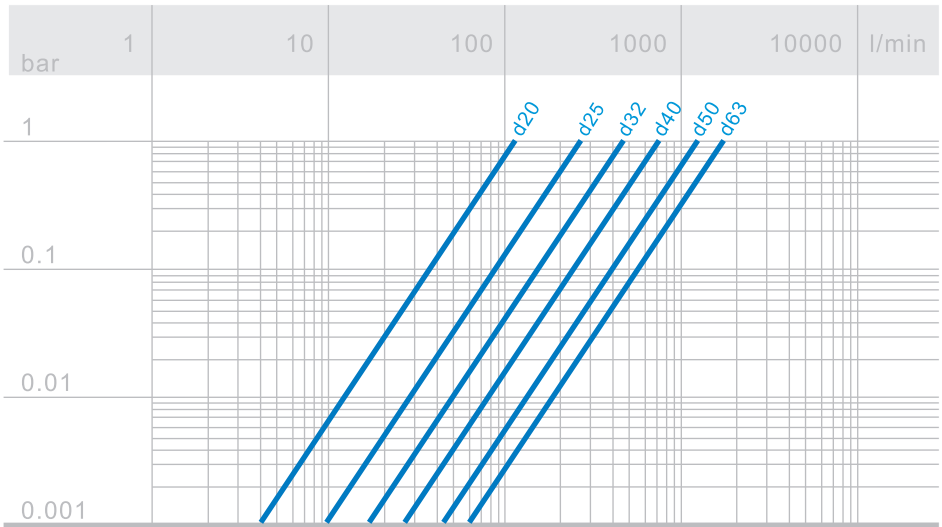

相對流量 線性圖

相對流量線性係數是指
流量作為閥門開啟行程
的函數的變化。

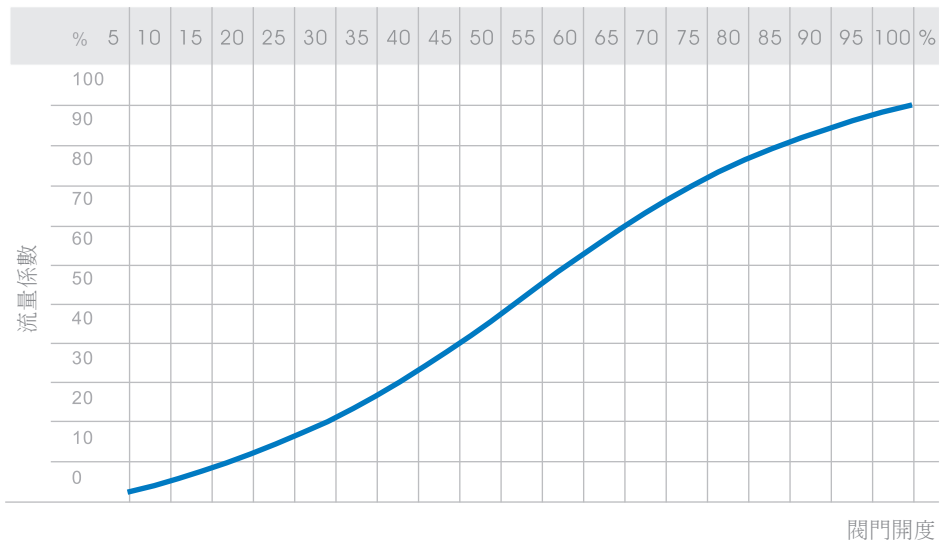

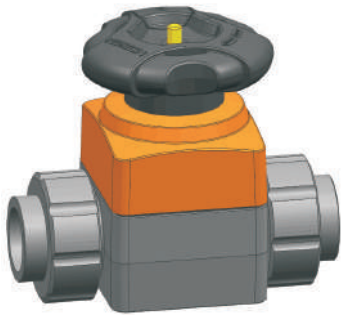

PVC-U 手動隔膜閥
 雙由令/膠粘承插端 Union Socket-end
 公制 DIN

<i>d</i> (mm)	<i>DN</i> (mm)	<i>PN</i> (bar)	<i>EPDM(per)</i>	<i>FPM(70)</i>	<i>EPDM-PTFE</i>	<i>KG</i>
20	15	10	301.020.1020	301.040.1020	301.060.1020	0,3
25	20	10	301.020.1025	301.040.1025	301.060.1025	0,5
32	25	10	301.020.1032	301.040.1032	301.060.1032	1,0
40	32	10	301.020.1040	301.040.1040	301.060.1040	1,1
50	40	10	301.020.1050	301.040.1050	301.060.1050	2,3
63	50	10	301.020.1063	301.040.1063	301.060.1063	2,6

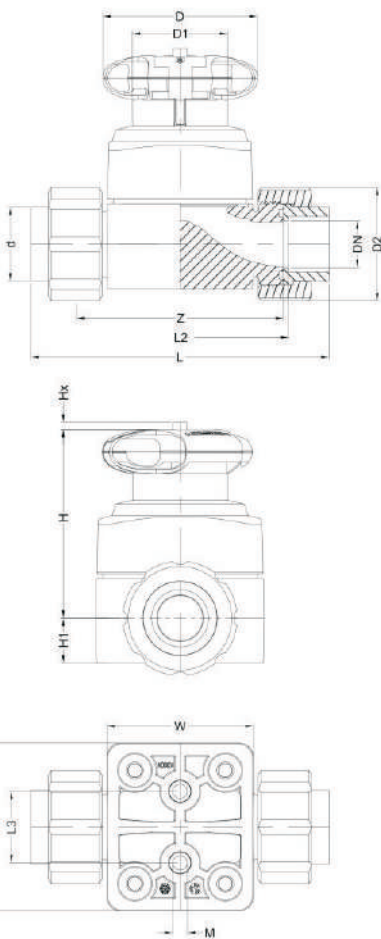

PVC-U 手動隔膜閥
 雙由令/膠粘承插端 Union Socket-end
 日標 JIS

<i>d</i> (mm)	<i>DN</i> (mm)	<i>PN</i> (bar)	<i>EPDM(per)</i>	<i>FPM(70)</i>	<i>EPDM-PTFE</i>	<i>KG</i>
20	15	10	301.020.1220	301.040.1220	301.060.1220	0,3
25	20	10	301.020.1225	301.040.1225	301.060.1225	0,5
32	25	10	301.020.1232	301.040.1232	301.060.1232	1,0
40	32	10	301.020.1240	301.040.1240	301.060.1240	1,1
50	40	10	301.020.1250	301.040.1250	301.060.1250	2,3
63	50	10	301.020.1263	301.040.1263	301.060.1263	2,6

PVC-U 手動隔膜閥
 雙由令/膠粘承插端 Union Socket-end
 美標 ANSI

<i>d</i> (mm)	<i>DN</i> (mm)	<i>PN</i> (bar)	<i>EPDM(per)</i>	<i>FPM(70)</i>	<i>EPDM-PTFE</i>	<i>KG</i>
1/2	15	10	301.020.1420	301.040.1420	301.060.1420	0,3
3/4	20	10	301.020.1425	301.040.1425	301.060.1425	0,5
1	25	10	301.020.1432	301.040.1432	301.060.1432	1,0
1-1/4	32	10	301.020.1440	301.040.1440	301.060.1440	1,1
1-1/2	40	10	301.020.1450	301.040.1450	301.060.1450	2,3
2	50	10	301.020.1463	301.040.1463	301.060.1463	2,6

Unit: mm

<i>d</i>	<i>DN</i>	<i>G</i>	<i>D</i>	<i>D1</i>	<i>D2</i>	<i>H</i>	<i>H1</i>	<i>L</i>	<i>L2</i>	<i>L3</i>	<i>M</i>	<i>Z</i>	<i>W</i>	<i>W1</i>	<i>Lift = Hx</i>
20	15	1	65	37	43	73	14	128	96	25	6	90	57	57	7
25	20	1-1/4	65	37	51	81	18	152	114	25	6	108	70	70	10
32	25	1-1/2	87	54	58	115	26	166	122	45	8	116	82	94	15
40	32	2	87	54	72	115	26	192	140	45	8	134	82	94	15
50	40	2-1/4	135	69	83	166	39	222	160	45	8	154	109	122	23
63	50	2-3/4	135	69	100	166	39	266	190	45	8	184	109	122	23



PVC-U 手動隔膜閥
 膠粘直插端 Spigot-DIN
 公制 DIN

<i>d</i> (mm)	<i>DN</i> (mm)	<i>PN</i> (bar)	<i>EPDM(per)</i>	<i>FPM(70)</i>	<i>EPDM-PTFE</i>	<i>KG</i>
20	15	10	301.020.5020	301.040.5020	301.060.5020	0,3
25	20	10	301.020.5025	301.040.5025	301.060.5025	0,4
32	25	10	301.020.5032	301.040.5032	301.060.5032	0,9
40	32	10	301.020.5040	301.040.5040	301.060.5040	0,9
50	40	10	301.020.5050	301.040.5050	301.060.5050	2,1
63	50	10	301.020.5063	301.040.5063	301.060.5063	2,2

Unit: mm

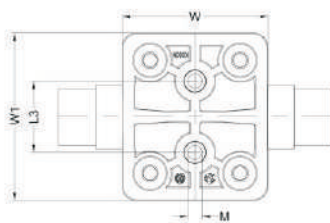
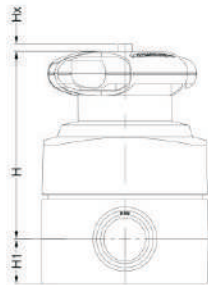
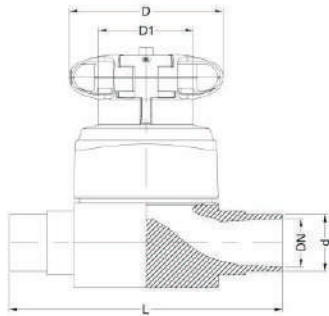

<i>d</i>	<i>DN</i>	<i>D</i>	<i>D1</i>	<i>H</i>	<i>H1</i>	<i>L</i>	<i>L3</i>	<i>M</i>	<i>W</i>	<i>W1</i>	<i>Hx</i>
20	15	65	37	73	14	124	25	6	57	57	7
25	20	65	37	81	18	144	25	6	70	70	10
32	25	87	54	115	26	164	45	8	82	94	15
40	32	87	54	115	26	174	45	8	82	94	15
50	40	135	69	166	39	204	45	8	109	122	23
63	50	135	69	166	39	224	45	8	109	122	23



PVC-U 手動隔膜閥
活套式法蘭 Flange
公制 DIN

<i>d</i> (mm)	<i>DN</i> (mm)	<i>PN</i> (bar)	<i>EPDM(per)</i>	<i>FPM(70)</i>	<i>EPDM-PTFE</i>	<i>KG</i>
20	15	10	301.020.7020	301.040.7020	301.060.7020	0,8
25	20	10	301.020.7025	301.040.7025	301.060.7025	1,1
32	25	10	301.020.7032	301.040.7032	301.060.7032	1,8
40	32	10	301.020.7040	301.040.7040	301.060.7040	2,3
50	40	10	301.020.7050	301.040.7050	301.060.7050	3,7
63	50	10	301.020.7063	301.040.7063	301.060.7063	4,1

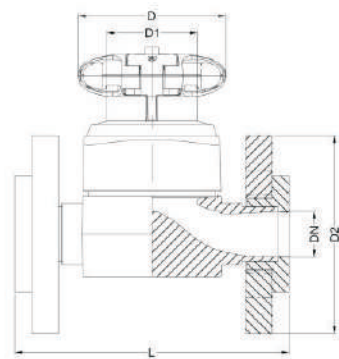

PVC-U 手動隔膜閥
活套式法蘭 Flange
日標 JIS

<i>d</i> (mm)	<i>DN</i> (mm)	<i>PN</i> (bar)	<i>EPDM(per)</i>	<i>FPM(70)</i>	<i>EPDM-PTFE</i>	<i>KG</i>
20	15	10	301.020.7220	301.040.7220	301.060.7220	0,8
25	20	10	301.020.7225	301.040.7225	301.060.7225	1,1
32	25	10	301.020.7232	301.040.7232	301.060.7232	1,8
40	32	10	301.020.7240	301.040.7240	301.060.7240	2,3
50	40	10	301.020.7250	301.040.7250	301.060.7250	3,7
63	50	10	301.020.7263	301.040.7263	301.060.7263	4,1

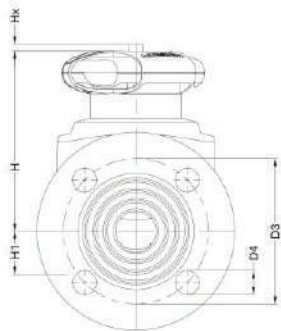

PVC-U 手動隔膜閥
活套式法蘭 Flange
美標 ANSI

<i>d</i> (mm)	<i>DN</i> (mm)	<i>PN</i> (bar)	<i>EPDM(per)</i>	<i>FPM(70)</i>	<i>EPDM-PTFE</i>	<i>KG</i>
1/2	15	10	301.020.7420	301.040.7420	301.060.7420	0,8
3/4	20	10	301.020.7425	301.040.7425	301.060.7425	1,1
1	25	10	301.020.7432	301.040.7432	301.060.7432	1,8
1-1/4	32	10	301.020.7440	301.040.7440	301.060.7440	2,3
1-1/2	40	10	301.020.7450	301.040.7450	301.060.7450	3,7
2	50	10	301.020.7463	301.040.7463	301.060.7463	4,1

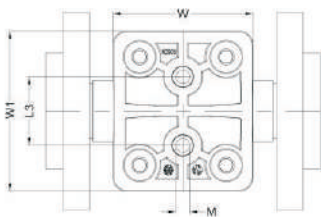

Unit: mm

<i>d</i>	<i>DN</i>	<i>D</i>	<i>D1</i>	<i>D2</i>	<i>D3_DIN</i>	<i>D3_JIS</i>	<i>D3_ANSI</i>	<i>D4</i>	<i>H</i>	<i>H1</i>	<i>L</i>	<i>L3</i>	<i>M</i>	<i>W</i>	<i>W1</i>	<i>Lift = Hx</i>
20	15	65	37	95	65	70	60,45	14`16	73	14	130	25	6	57	57	7
25	20	65	37	105	75	75	69,85	14`16	81	18	150	25	6	70	70	10
32	25	87	54	115	85	90	79,25	14`19	115	26	170	45	8	82	94	15
40	32	87	54	140	100	100	88,90	16`19	115	26	180	45	8	82	94	15
50	40	135	69	150	110	105	98,55	16`19	166	39	210	45	8	109	122	23
63	50	135	69	165	125	120	120,65	18`20	166	39	230	45	8	109	122	23

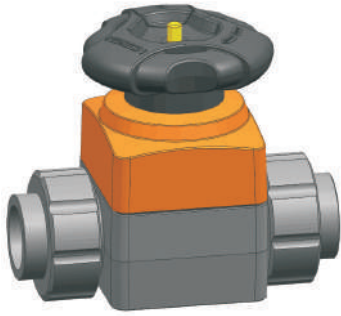

PVC-C 手動隔膜閥
 雙由令/膠粘承插端 Union Socket-end
 公制 DIN

<i>d</i> (mm)	<i>DN</i> (mm)	<i>PN</i> (bar)	<i>EPDM(per)</i>	<i>FPM(70)</i>	<i>EPDM-PTFE</i>	<i>KG</i>
20	15	10	301.220.1020	301.240.1020	301.260.1020	0,3
25	20	10	301.220.1025	301.240.1025	301.260.1025	0,5
32	25	10	301.220.1032	301.240.1032	301.260.1032	1,0
40	32	10	301.220.1040	301.240.1040	301.260.1040	1,1
50	40	10	301.220.1050	301.240.1050	301.260.1050	2,3
63	50	10	301.220.1063	301.240.1063	301.260.1063	2,6

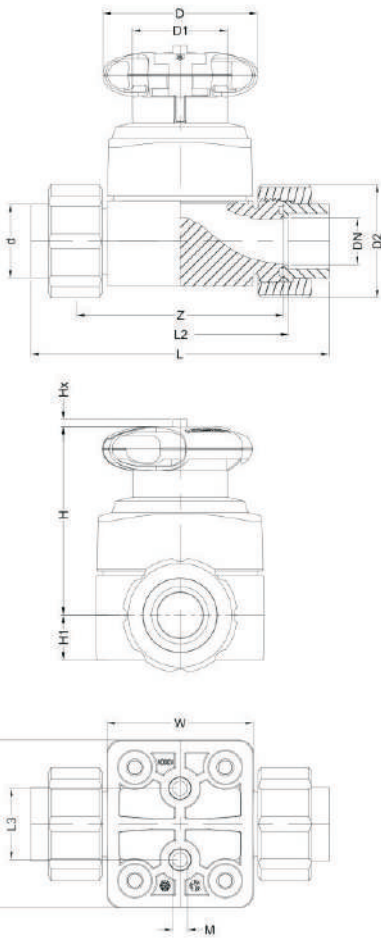

PVC-C 手動隔膜閥
 雙由令/膠粘承插端 Union Socket-end
 日標 JIS

<i>d</i> (mm)	<i>DN</i> (mm)	<i>PN</i> (bar)	<i>EPDM(per)</i>	<i>FPM(70)</i>	<i>EPDM-PTFE</i>	<i>KG</i>
20	15	10	301.220.1220	301.240.1220	301.260.1220	0,3
25	20	10	301.220.1225	301.240.1225	301.260.1225	0,5
32	25	10	301.220.1232	301.240.1232	301.260.1232	1,0
40	32	10	301.220.1240	301.240.1240	301.260.1240	1,1
50	40	10	301.220.1250	301.240.1250	301.260.1250	2,3
63	50	10	301.220.1263	301.240.1263	301.260.1263	2,6

PVC-C 手動隔膜閥
 雙由令/膠粘承插端 Union Socket-end
 美標 ANSI

<i>d</i> (mm)	<i>DN</i> (mm)	<i>PN</i> (bar)	<i>EPDM(per)</i>	<i>FPM(70)</i>	<i>EPDM-PTFE</i>	<i>KG</i>
1/2	15	10	301.220.1420	301.240.1420	301.260.1420	0,3
3/4	20	10	301.220.1425	301.240.1425	301.260.1425	0,5
1	25	10	301.220.1432	301.240.1432	301.260.1432	1,0
1-1/4	32	10	301.220.1440	301.240.1440	301.260.1440	1,1
1-1/2	40	10	301.220.1450	301.240.1450	301.260.1450	2,3
2	50	10	301.220.1463	301.240.1463	301.260.1463	2,6

Unit: mm

<i>d</i>	<i>DN</i>	<i>G</i>	<i>D</i>	<i>D1</i>	<i>D2</i>	<i>H</i>	<i>H1</i>	<i>L</i>	<i>L2</i>	<i>L3</i>	<i>M</i>	<i>Z</i>	<i>W</i>	<i>W1</i>	<i>Lift = Hx</i>
20	15	1	65	37	43	73	14	128	96	25	6	90	57	57	7
25	20	1-1/4	65	37	51	81	18	152	114	25	6	108	70	70	10
32	25	1-1/2	87	54	58	115	26	166	122	45	8	116	82	94	15
40	32	2	87	54	72	115	26	192	140	45	8	134	82	94	15
50	40	2-1/4	135	69	83	166	39	222	160	45	8	154	109	122	23
63	50	2-3/4	135	69	100	166	39	266	190	45	8	184	109	122	23



PVC-C 手動隔膜閥
活套式法蘭 Flange
公制 DIN

<i>d</i> (mm)	<i>DN</i> (mm)	<i>PN</i> (bar)	<i>EPDM(per)</i>	<i>FPM(70)</i>	<i>EPDM-PTFE</i>	<i>KG</i>
20	15	10	301.220.7020	301.240.7020	301.260.7020	0,8
25	20	10	301.220.7025	301.240.7025	301.260.7025	1,1
32	25	10	301.220.7032	301.240.7032	301.260.7032	1,8
40	32	10	301.220.7040	301.240.7040	301.260.7040	2,3
50	40	10	301.220.7050	301.240.7050	301.260.7050	3,7
63	50	10	301.220.7063	301.240.7063	301.260.7063	4,1

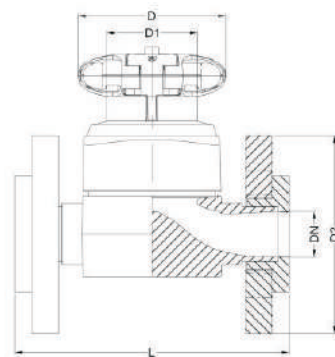

PVC-C 手動隔膜閥
活套式法蘭 Flange
日標 JIS

<i>d</i> (mm)	<i>DN</i> (mm)	<i>PN</i> (bar)	<i>EPDM(per)</i>	<i>FPM(70)</i>	<i>EPDM-PTFE</i>	<i>KG</i>
20	15	10	301.220.7220	301.240.7220	301.260.7220	0,8
25	20	10	301.220.7225	301.240.7225	301.260.7225	1,1
32	25	10	301.220.7232	301.240.7232	301.260.7232	1,8
40	32	10	301.220.7240	301.240.7240	301.260.7240	2,3
50	40	10	301.220.7250	301.240.7250	301.260.7250	3,7
63	50	10	301.220.7263	301.240.7263	301.260.7263	4,1

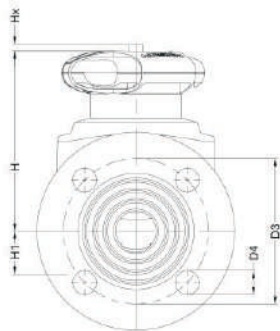

PVC-C 手動隔膜閥
活套式法蘭 Flange
美標 ANSI

<i>d</i> (mm)	<i>DN</i> (mm)	<i>PN</i> (bar)	<i>EPDM(per)</i>	<i>FPM(70)</i>	<i>EPDM-PTFE</i>	<i>KG</i>
1/2	15	10	301.220.7420	301.240.7420	301.260.7420	0,8
3/4	20	10	301.220.7425	301.240.7425	301.260.7425	1,1
1	25	10	301.220.7432	301.240.7432	301.260.7432	1,8
1-1/4	32	10	301.220.7440	301.240.7440	301.260.7440	2,3
1-1/2	40	10	301.220.7450	301.240.7450	301.260.7450	3,7
2	50	10	301.220.7463	301.240.7463	301.260.7463	4,1

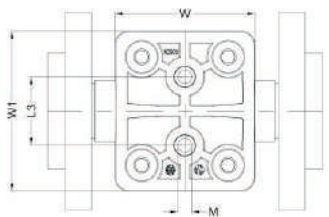

Unit: mm

<i>d</i>	<i>DN</i>	<i>D</i>	<i>D1</i>	<i>D2</i>	<i>D3</i> _{-DIN}	<i>D3</i> _{-JIS}	<i>D3</i> _{-ANSI}	<i>D4</i>	<i>H</i>	<i>H1</i>	<i>L</i>	<i>L3</i>	<i>M</i>	<i>W</i>	<i>W1</i>	<i>Lift = Hx</i>
20	15	65	37	95	65	70	60,45	14`16	73	14	130	25	6	57	57	7
25	20	65	37	105	75	75	69,85	14`16	81	18	150	25	6	70	70	10
32	25	87	54	115	85	90	79,25	14`19	115	26	170	45	8	82	94	15
40	32	87	54	140	100	100	88,90	16`19	115	26	180	45	8	82	94	15
50	40	135	69	150	110	105	98,55	16`19	166	39	210	45	8	109	122	23
63	50	135	69	165	125	120	120,65	18`20	166	39	230	45	8	109	122	23

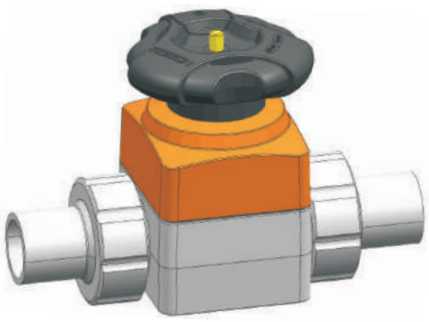

PP-H 手動隔膜閥

雙由令/承插熔接端 Union Socket-end

公制 DIN

<i>d</i> (mm)	<i>DN</i> (mm)	<i>PN</i> (bar)	<i>EPDM(per)</i>	<i>FPM(70)</i>	<i>EPDM-PTFE</i>	<i>KG</i>
20	15	10	301.420.1020	301.440.1020	301.460.1020	0,3
25	20	10	301.420.1025	301.440.1025	301.460.1025	0,5
32	25	10	301.420.1032	301.440.1032	301.460.1032	0,9
40	32	10	301.420.1040	301.440.1040	301.460.1040	1,0
50	40	10	301.420.1050	301.440.1050	301.460.1050	2,0
63	50	10	301.420.1063	301.440.1063	301.460.1063	2,3

PP-H 手動隔膜閥

雙由令/對焊熔接端 Union Spigot Butt+IR

公制 DIN

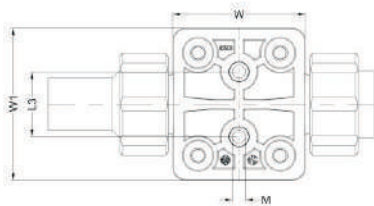
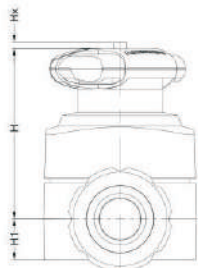
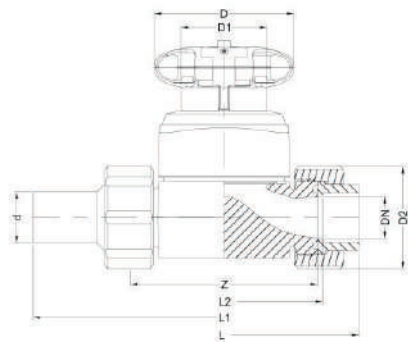

<i>d</i> (mm)	<i>DN</i> (mm)	<i>PN</i> (bar)	<i>EPDM(per)</i>	<i>FPM(70)</i>	<i>EPDM-PTFE</i>	<i>KG</i>
20	15	10	301.420.3020	301.440.3020	301.460.3020	0,3
25	20	10	301.420.3025	301.440.3025	301.460.3025	0,5
32	25	10	301.420.3032	301.440.3032	301.460.3032	0,9
40	32	10	301.420.3040	301.440.3040	301.460.3040	1,0
50	40	10	301.420.3050	301.440.3050	301.460.3050	2,0
63	50	10	301.420.3063	301.440.3063	301.460.3063	2,3

PP-H 手動禁油隔膜閥

雙由令/對焊熔接端 Union Spigot Butt+IR

公制 DIN

<i>d</i> (mm)	<i>DN</i> (mm)	<i>PN</i> (bar)	<i>EPDM-PTFE</i>	<i>KG</i>
20	15	10	301.460.3020.010	0,3
25	20	10	301.460.3025.010	0,5
32	25	10	301.460.3032.010	0,9
40	32	10	301.460.3040.010	1,0
50	40	10	301.460.3050.010	2,0
63	50	10	301.460.3063.010	2,3

Unit: mm

<i>d</i>	<i>DN</i>	<i>G</i>	<i>D</i>	<i>D1</i>	<i>D2</i>	<i>H</i>	<i>H1</i>	<i>L</i>	<i>L2</i>	<i>L3</i>	<i>M</i>	<i>Z</i>	<i>W</i>	<i>W1</i>	<i>Lift = Hx</i>
20	15	1	65	37	43	73	14	128	96	25	6	90	57	57	7
25	20	1-1/4	65	37	51	81	18	152	114	25	6	108	70	70	10
32	25	1-1/2	87	54	58	115	26	166	122	45	8	116	82	94	15
40	32	2	87	54	72	115	26	192	140	45	8	134	82	94	15
50	40	2-1/4	135	69	83	166	39	222	160	45	8	154	109	122	23
63	50	2-3/4	135	69	100	166	39	266	190	45	8	184	109	122	23

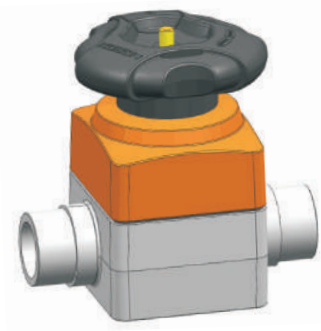

PP-H 手動隔膜閥
 直通口/對焊熔接端 Spigot Butt+IR
 公制 DIN

<i>d</i> (mm)	<i>DN</i> (mm)	<i>PN</i> (bar)	<i>EPDM(per)</i>	<i>FPM(70)</i>	<i>EPDM-PTFE</i>	<i>KG</i>
20	15	10	301.420.5020	301.440.5020	301.460.5020	0,3
25	20	10	301.420.5025	301.440.5025	301.460.5025	0,4
32	25	10	301.420.5032	301.440.5032	301.460.5032	0,7
40	32	10	301.420.5040	301.440.5040	301.460.5040	0,8
50	40	10	301.420.5050	301.440.5050	301.460.5050	1,8
63	50	10	301.420.5063	301.440.5063	301.460.5063	1,9

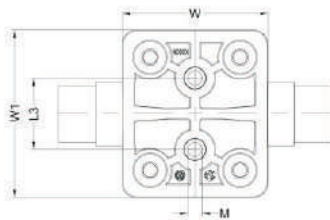
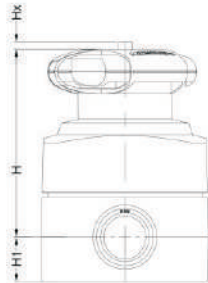
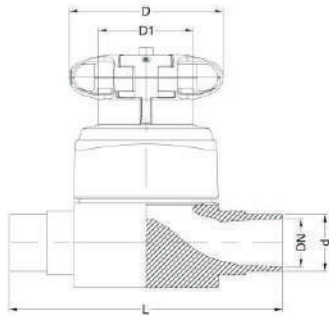

Unit: mm

<i>d</i>	<i>DN</i>	<i>D</i>	<i>D1</i>	<i>H</i>	<i>H1</i>	<i>L</i>	<i>L3</i>	<i>M</i>	<i>W</i>	<i>W1</i>	<i>Hx</i>
20	15	65	37	73	14	124	25	6	57	57	7
25	20	65	37	81	18	144	25	6	70	70	10
32	25	87	54	115	26	164	45	8	82	94	15
40	32	87	54	115	26	174	45	8	82	94	15
50	40	135	69	166	39	204	45	8	109	122	23
63	50	135	69	166	39	224	45	8	109	122	23

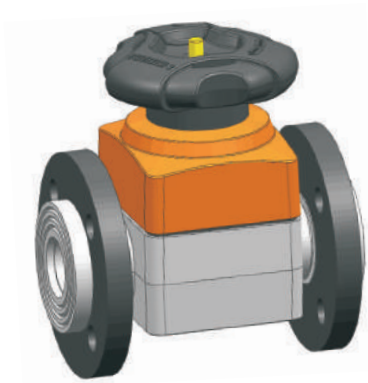

PP-H 手動隔膜閥
活套式法蘭 Flange
公制 DIN

<i>d</i> (mm)	<i>DN</i> (mm)	<i>PN</i> (bar)	<i>EPDM(per)</i>	<i>FPM(70)</i>	<i>EPDM-PTFE</i>	<i>KG</i>
20	15	10	301.420.7020	301.440.7020	301.460.7020	0,8
25	20	10	301.420.7025	301.440.7025	301.460.7025	1,0
32	25	10	301.420.7032	301.440.7032	301.460.7032	1,7
40	32	10	301.420.7040	301.440.7040	301.460.7040	2,2
50	40	10	301.420.7050	301.440.7050	301.460.7050	3,3
63	50	10	301.420.7063	301.440.7063	301.460.7063	3,6

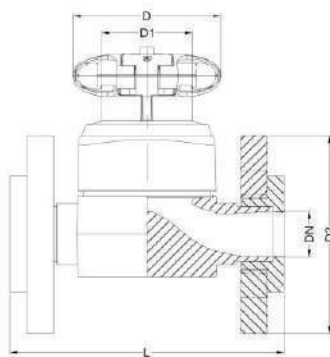

PP-H 手動隔膜閥
活套式法蘭 Flange
日標 JIS

<i>d</i> (mm)	<i>DN</i> (mm)	<i>PN</i> (bar)	<i>EPDM(per)</i>	<i>FPM(70)</i>	<i>EPDM-PTFE</i>	<i>KG</i>
20	15	10	301.420.7220	301.440.7220	301.460.7220	0,8
25	20	10	301.420.7225	301.440.7225	301.460.7225	1,0
32	25	10	301.420.7232	301.440.7232	301.460.7232	1,7
40	32	10	301.420.7240	301.440.7240	301.460.7240	2,2
50	40	10	301.420.7250	301.440.7250	301.460.7250	3,3
63	50	10	301.420.7263	301.440.7263	301.460.7263	3,6

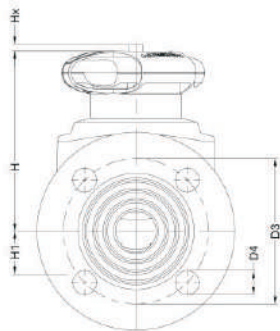

PP-H 手動隔膜閥
活套式法蘭 Flange
美標 ANSI

<i>d</i> (mm)	<i>DN</i> (mm)	<i>PN</i> (bar)	<i>EPDM(per)</i>	<i>FPM(70)</i>	<i>EPDM-PTFE</i>	<i>KG</i>
1/2	15	10	301.420.7420	301.440.7420	301.460.7420	0,8
3/4	20	10	301.420.7425	301.440.7425	301.460.7425	1,0
1	25	10	301.420.7432	301.440.7432	301.460.7432	1,7
1-1/4	32	10	301.420.7440	301.440.7440	301.460.7440	2,2
1-1/2	40	10	301.420.7450	301.440.7450	301.460.7450	3,3
2	50	10	301.420.7463	301.440.7463	301.460.7463	3,6

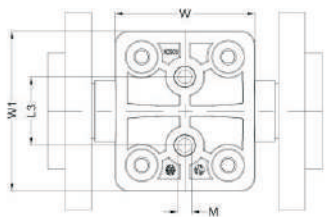

Unit: mm

<i>d</i>	<i>DN</i>	<i>D</i>	<i>D1</i>	<i>D2</i>	<i>D3_DIN</i>	<i>D3_JIS</i>	<i>D3_ANSI</i>	<i>D4</i>	<i>H</i>	<i>H1</i>	<i>L</i>	<i>L3</i>	<i>M</i>	<i>W</i>	<i>W1</i>	<i>Lift = Hx</i>
20	15	65	37	95	65	70	60,45	14`16	73	14	130	25	6	57	57	7
25	20	65	37	105	75	75	69,85	14`16	81	18	150	25	6	70	70	10
32	25	87	54	115	85	90	79,25	14`19	115	26	170	45	8	82	94	15
40	32	87	54	140	100	100	88,90	16`19	115	26	180	45	8	82	94	15
50	40	135	69	150	110	105	98,55	16`19	166	39	210	45	8	109	122	23
63	50	135	69	165	125	120	120,65	18`20	166	39	230	45	8	109	122	23

PP-Natural 手動隔膜閥

雙由令/承插熔接端 Union Socket-end

公制 DIN

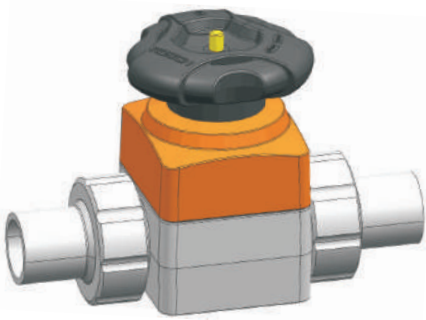

<i>d</i> (mm)	<i>DN</i> (mm)	<i>PN</i> (bar)	<i>EPDM(per)</i>	<i>EPDM-PTFE</i>	<i>KG</i>
20	15	10	301.520.1020	301.560.1020	0,3
25	20	10	301.520.1025	301.560.1025	0,5
32	25	10	301.520.1032	301.560.1032	0,9
40	32	10	301.520.1040	301.560.1040	1,0
50	40	10	301.520.1050	301.560.1050	2,0
63	50	10	301.520.1063	301.560.1063	2,3

PP-Natural 手動隔膜閥

雙由令/承插熔接端 Union Spigot Butt+IR

公制 DIN

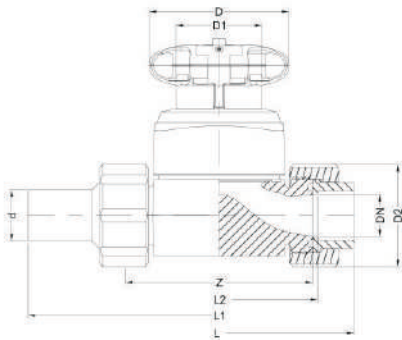

<i>d</i> (mm)	<i>DN</i> (mm)	<i>PN</i> (bar)	<i>EPDM(per)</i>	<i>EPDM-PTFE</i>	<i>KG</i>
20	15	10	301.520.3020	301.560.3020	0,3
25	20	10	301.520.3025	301.560.3025	0,5
32	25	10	301.520.3032	301.560.3032	0,9
40	32	10	301.520.3040	301.560.3040	1,0
50	40	10	301.520.3050	301.560.3050	2,0
63	50	10	301.520.3063	301.560.3063	2,3

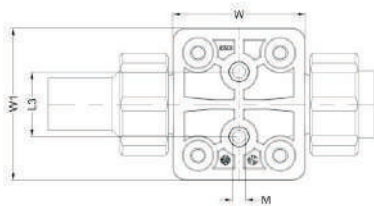
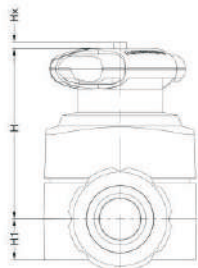

PP-Natural 手動禁油隔膜閥

雙由令/對焊熔接端 Union Spigot Butt+IR

公制 DIN

<i>d</i> (mm)	<i>DN</i> (mm)	<i>PN</i> (bar)	<i>EPDM-PTFE</i>	<i>KG</i>
20	15	10	301.560.3020.010	0,3
25	20	10	301.560.3025.010	0,5
32	25	10	301.560.3032.010	0,9
40	32	10	301.560.3040.010	1,0
50	40	10	301.560.3050.010	2,0
63	50	10	301.560.3063.010	2,3

Unit: mm

<i>d</i>	<i>DN</i>	<i>G</i>	<i>D</i>	<i>D1</i>	<i>D2</i>	<i>H</i>	<i>H1</i>	<i>L</i>	<i>L2</i>	<i>L3</i>	<i>M</i>	<i>Z</i>	<i>W</i>	<i>W1</i>	<i>Lift = Hx</i>
20	15	1	65	37	43	73	14	128	96	25	6	90	57	57	7
25	20	1-1/4	65	37	51	81	18	152	114	25	6	108	70	70	10
32	25	1-1/2	87	54	58	115	26	166	122	45	8	116	82	94	15
40	32	2	87	54	72	115	26	192	140	45	8	134	82	94	15
50	40	2-1/4	135	69	83	166	39	222	160	45	8	154	109	122	23
63	50	2-3/4	135	69	100	166	39	266	190	45	8	184	109	122	23

PVDF 手動隔膜閥

雙由令/承插熔接端 Union Socket-end
公制 DIN

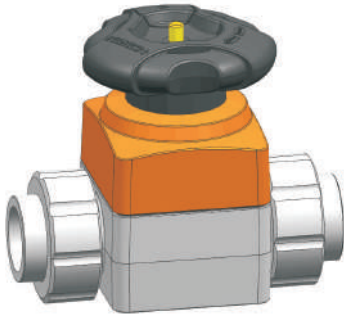

<i>d</i> (mm)	<i>DN</i> (mm)	<i>PN</i> (bar)	<i>EPDM(per)</i>	<i>EPDM-PTFE</i>	<i>KG</i>
20	15	16	301.640.1020	301.660.1020	0,4
25	20	16	301.640.1025	301.660.1025	0,6
32	25	16	301.640.1032	301.660.1032	1,2
40	32	16	301.640.1040	301.660.1040	1,4
50	40	16	301.640.1050	301.660.1050	2,7
63	50	16	301.640.1063	301.660.1063	3,0

PVDF 手動隔膜閥

雙由令/對焊熔接端 Union Spigot Butt+IR
公制 DIN

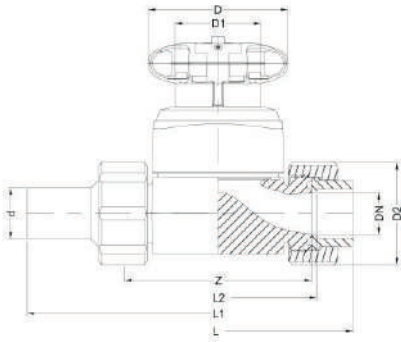

<i>d</i> (mm)	<i>DN</i> (mm)	<i>PN</i> (bar)	<i>EPDM(per)</i>	<i>EPDM-PTFE</i>	<i>KG</i>
20	15	16	301.640.3020	301.660.3020	0,4
25	20	16	301.640.3025	301.660.3025	0,6
32	25	16	301.640.3032	301.660.3032	1,2
40	32	16	301.640.3040	301.660.3040	1,4
50	40	16	301.640.3050	301.660.3050	2,7
63	50	16	301.640.3063	301.660.3063	3,0

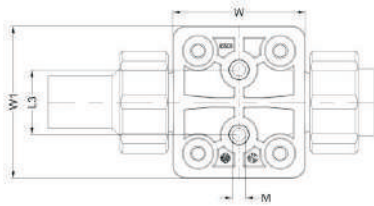
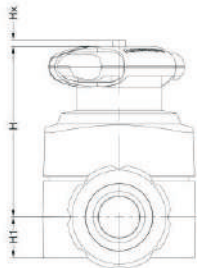

PVDF 手動禁油隔膜閥

雙由令/對焊熔接端 Union Spigot Butt+IR
公制 DIN

<i>d</i> (mm)	<i>DN</i> (mm)	<i>PN</i> (bar)	<i>EPDM-PTFE</i>	<i>KG</i>
20	15	16	301.660.3020.010	0,4
25	20	16	301.660.3025.010	0,6
32	25	16	301.660.3032.010	1,2
40	32	16	301.660.3040.010	1,4
50	40	16	301.660.3050.010	2,7
63	50	16	301.660.3063.010	3,0

Unit: mm

<i>d</i>	<i>DN</i>	<i>G</i>	<i>D</i>	<i>D1</i>	<i>D2</i>	<i>H</i>	<i>H1</i>	<i>L</i>	<i>L2</i>	<i>L3</i>	<i>M</i>	<i>Z</i>	<i>W</i>	<i>W1</i>	<i>Lift = Hx</i>
20	15	1	65	37	43	73	14	128	96	25	6	90	57	57	7
25	20	1-1/4	65	37	51	81	18	152	114	25	6	108	70	70	10
32	25	1-1/2	87	54	58	115	26	166	122	45	8	116	82	94	15
40	32	2	87	54	72	115	26	192	140	45	8	134	82	94	15
50	40	2-1/4	135	69	83	166	39	222	160	45	8	154	109	122	23
63	50	2-3/4	135	69	100	166	39	266	190	45	8	184	109	122	23



PVDF 手動隔膜閥
直通口/對焊熔接端 Spigot Butt+IR
公制 DIN

<i>d</i> (mm)	<i>DN</i> (mm)	<i>PN</i> (bar)	<i>FPM(70)</i>	<i>EPDM-PTFE</i>	<i>KG</i>
20	15	16	301.640.5020	301.660.5020	0,3
25	20	16	301.640.5025	301.660.5025	0,5
32	25	16	301.640.5032	301.660.5032	1,0
40	32	16	301.640.5040	301.660.5040	1,1
50	40	16	301.640.5050	301.660.5050	2,3
63	50	16	301.640.5063	301.660.5063	2,5

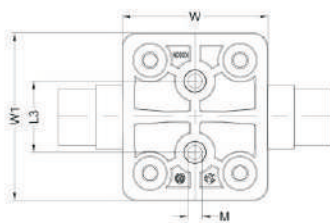
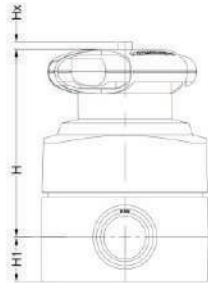
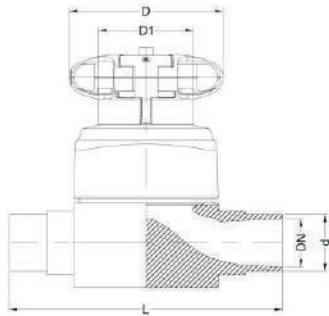

Unit: mm

<i>d</i>	<i>DN</i>	<i>D</i>	<i>D1</i>	<i>H</i>	<i>H1</i>	<i>L</i>	<i>L3</i>	<i>M</i>	<i>W</i>	<i>W1</i>	<i>Hx</i>
20	15	65	37	73	14	124	25	6	57	57	7
25	20	65	37	81	18	144	25	6	70	70	10
32	25	87	54	115	26	164	45	8	82	94	15
40	32	87	54	115	26	174	45	8	82	94	15
50	40	135	69	166	39	204	45	8	109	122	23
63	50	135	69	166	39	224	45	8	109	122	23



PVDF 手動隔膜閥
活套式法蘭 Flange
公制 DIN

<i>d</i> (mm)	<i>DN</i> (mm)	<i>PN</i> (bar)	<i>FPM(70)</i>	<i>EPDM-PTFE</i>	<i>KG</i>
20	15	16	301.640.7020	301.660.7020	0,8
25	20	16	301.640.7025	301.660.7025	1,2
32	25	16	301.640.7032	301.660.7032	1,9
40	32	16	301.640.7040	301.660.7040	2,5
50	40	16	301.640.7050	301.660.7050	3,9
63	50	16	301.640.7063	301.660.7063	4,4

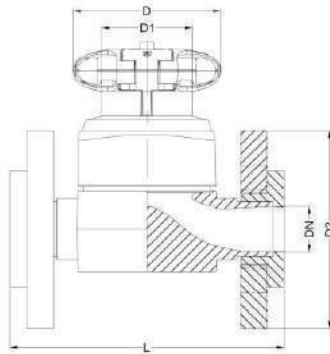

PVDF 手動隔膜閥
活套式法蘭 Flange
日標 JIS

<i>d</i> (mm)	<i>DN</i> (mm)	<i>PN</i> (bar)	<i>FPM(70)</i>	<i>EPDM-PTFE</i>	<i>KG</i>
20	15	16	301.640.7220	301.660.7220	
25	20	16	301.640.7225	301.660.7225	
32	25	16	301.640.7232	301.660.7232	
40	32	16	301.640.7240	301.660.7240	
50	40	16	301.640.7250	301.660.7250	
63	50	16	301.640.7263	301.660.7263	

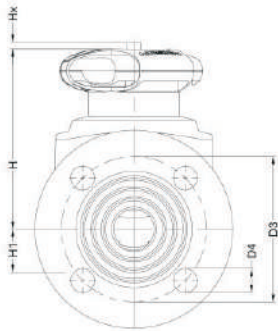

PVDF 手動隔膜閥
活套式法蘭 Flange
美標 ANSI

<i>d</i> (mm)	<i>DN</i> (mm)	<i>PN</i> (bar)	<i>FPM(70)</i>	<i>EPDM-PTFE</i>	<i>KG</i>
1/2	15	16	301.640.7420	301.660.7420	
3/4	20	16	301.640.7425	301.660.7425	
1	25	16	301.640.7432	301.660.7432	
1-1/4	32	16	301.640.7440	301.660.7440	
1-1/2	40	16	301.640.7450	301.660.7450	
2	50	16	301.640.7463	301.660.7463	

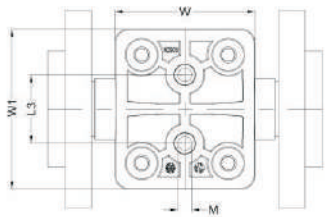

Unit: mm

<i>d</i>	<i>DN</i>	<i>D</i>	<i>D1</i>	<i>D2</i>	<i>D3</i> _{-DIN}	<i>D3</i> _{-JIS}	<i>D3</i> _{-ANSI}	<i>D4</i>	<i>H</i>	<i>H1</i>	<i>L</i>	<i>L3</i>	<i>M</i>	<i>W</i>	<i>W1</i>	<i>Lift = Hx</i>
20	15	65	37	95	65	70	60,45	14`16	73	14	130	25	6	57	57	7
25	20	65	37	105	75	75	69,85	14`16	81	18	150	25	6	70	70	10
32	25	87	54	115	85	90	79,25	14`19	115	26	170	45	8	82	94	15
40	32	87	54	140	100	100	88,90	16`19	115	26	180	45	8	82	94	15
50	40	135	69	150	110	105	98,55	16`19	166	39	210	45	8	109	122	23
63	50	135	69	165	125	120	120,65	18`20	166	39	230	45	8	109	122	23

