

Environmental technology

**Manual Butterfly valve
KV 400**

**Electric Butterfly valve
KV 401**

**Pneumatic Butterfly valve
KV 402**



KOSCN Control Valves KV400 butterfly valve is an economical product for environmental technology application, suitable for pure waste water system and weak corrosive medium application. It can be modularly expanded into electric and pneumatic control, and realize intelligent application, with functions of switch, regulation, signal feedback, automatic reset, fault alarm and others.

Easy installation and maintenance

- * The valve body carries out ISO and GB installation standards, universal through hole for easy installation
- * The handle has direction indication of switch
- * Using ISO5211 standard design, simple maintenance
- * Manual and automatic modules are replaceable for easy upgrade
- * Compact design of all plastic or aluminum actuators ensures mounting space

High safety performance

- * Valve shaft of stainless steel, corrosion resistant and variant
- * Seat double seal design, low torque, no leakage
- * Material and seal options are available for general applications other than pure chemical systems
- * Intelligent actuator through torque design, to ensure the safety of the application

High Flexibility

- * Valve body has PVC-U, PP-H
- * Connection type: DIN, ANSI, JIS
- * Pneumatic control: NC, NO, DA
- * Electric intelligent: switch, regulation, bus communication
- * Function options: signal feedback, power-off reset, fault alarm

+ Technical characteristics

Pressure temperature curve

All data based on water for consider -ring 25 years safe life time

Other liquids request to reduce the temperature and pressure accordingly

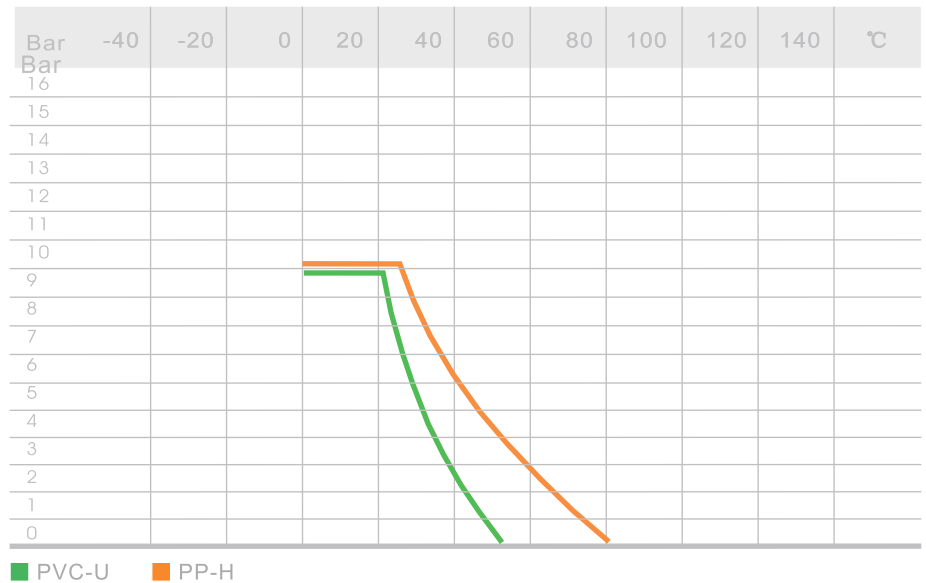

Flow capacity

All data are for 20°C water with 1 bar pressure difference

$$Cv = kv \times 0,07$$

$$Fv = kv \times 0,0585$$

Kv (l/min)

Cv (gal/min) US

Fv (gal/min) GB

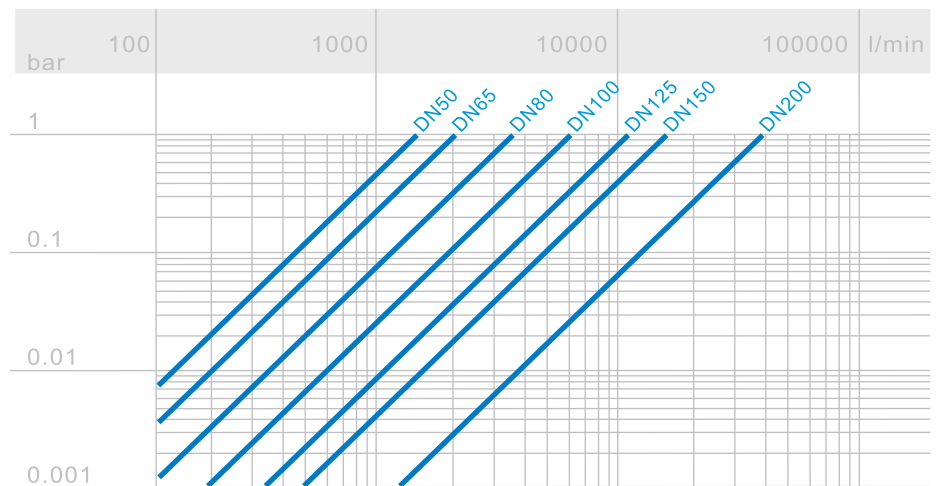

Line chart for relative flow rate

The linear coefficient of relative flow refers to the flow change as a function of valve opening stroke

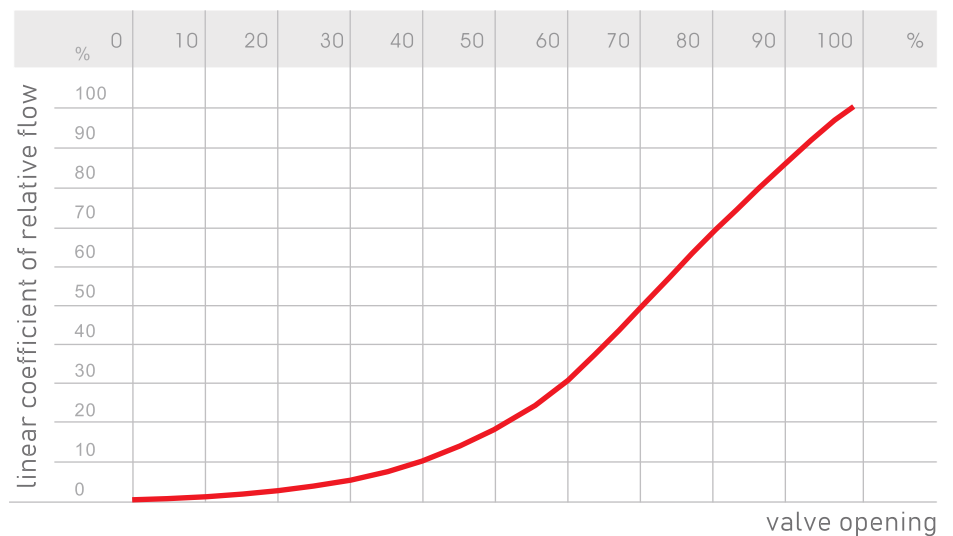

+ Configuration Pictogram

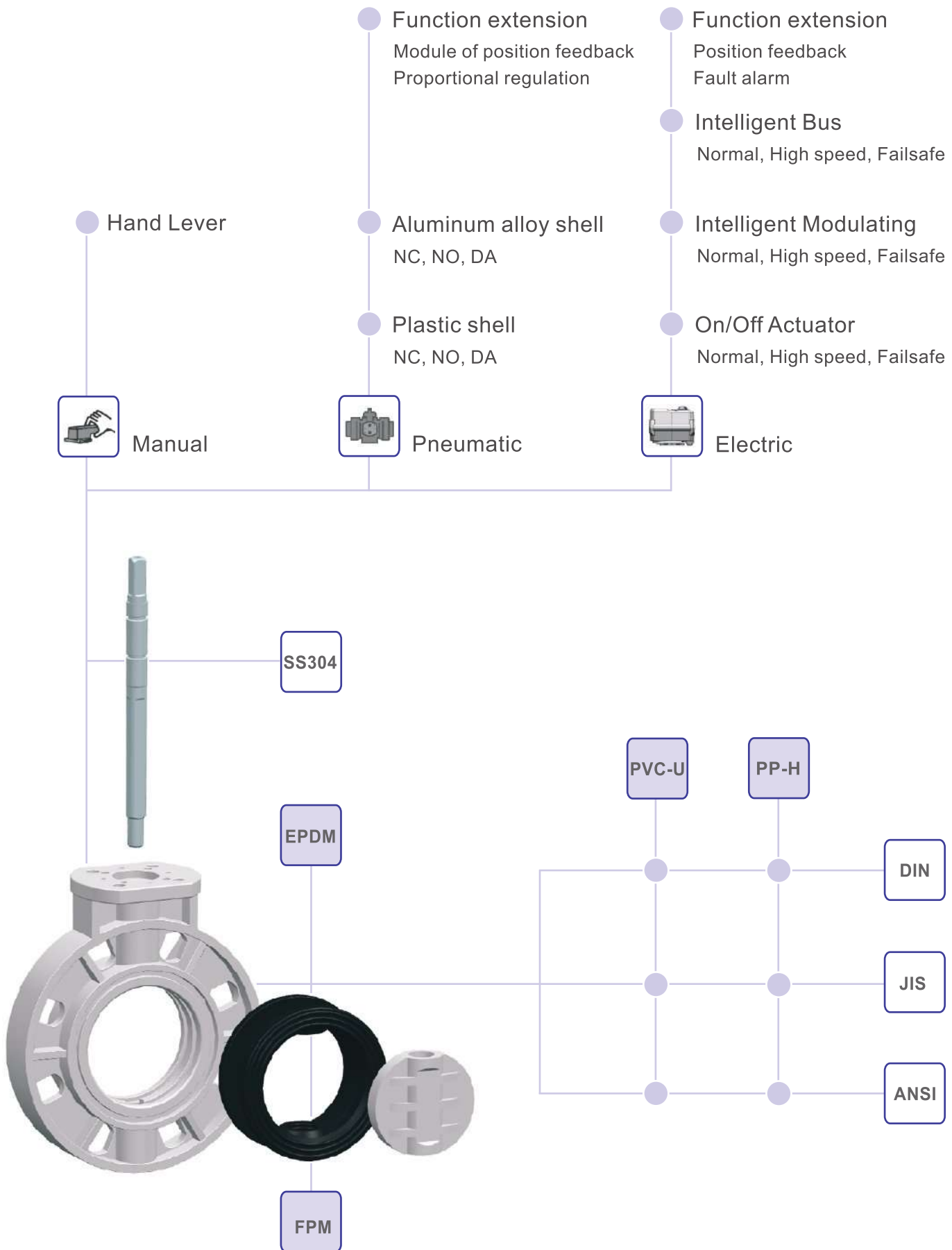



PVC-U Hand lever butterfly valve

Wafer type flange

DIN

<i>d</i> (mm)	<i>DN</i> (mm)	<i>PN</i> (bar)	<i>Stem</i>	<i>EPDM</i>	<i>FPM</i>
63	50	10	SS304	400.010.7063	400.030.7063
75	65	10	SS304	400.010.7075	400.030.7075
90	80	10	SS304	400.010.7090	400.030.7090
110	100	10	SS304	400.010.7011	400.030.7011
140	125	10	SS304	400.010.7014	400.030.7014
160	150	10	SS304	400.010.7016	400.030.7016
225	200	8	SS304	400.010.1022	400.030.1022

PVC-U Hand lever butterfly valve

Wafer type flange

JIS

<i>d</i> (mm)	<i>DN</i> (mm)	<i>PN</i> (bar)	<i>Stem</i>	<i>EPDM</i>	<i>FPM</i>
63	50	10	SS304	400.010.7263	400.030.7263
75	65	10	SS304	400.010.7275	400.030.7275
90	80	10	SS304	400.010.7290	400.030.7290
110	100	10	SS304	400.010.7211	400.030.7211
140	125	10	SS304	400.010.7214	400.030.7214
160	150	10	SS304	400.010.7216	400.030.7216
225	200	8	SS304	400.010.1222	400.030.1222

PVC-U Hand lever butterfly valve

Wafer type flange

ANSI

<i>d</i> (In)	<i>DN</i> (mm)	<i>PN</i> (bar)	<i>Stem</i>	<i>EPDM</i>	<i>FPM</i>
2	50	10	SS304	400.010.7063	400.030.7063
2-1/2	65	10	SS304	400.010.7075	400.030.7075
3	80	10	SS304	400.010.7090	400.030.7090
4	100	10	SS304	400.010.7011	400.030.7011
5	125	10	SS304	400.010.7014	400.030.7014
6	150	10	SS304	400.010.7016	400.030.7016
8	200	8	SS304	400.010.1022	400.030.1022



PP-H Hand lever butterfly valve

Wafer type flange

DIN

<i>d</i> (mm)	<i>DN</i> (mm)	<i>PN</i> (bar)	<i>Stem</i>	<i>EPDM</i>	<i>FPM</i>
63	50	10	SS304	400.410.7063	400.430.7063
75	65	10	SS304	400.410.7075	400.430.7075
90	80	10	SS304	400.410.7090	400.430.7090
110	100	10	SS304	400.410.7011	400.430.7011
140	125	10	SS304	400.410.7014	400.430.7014
160	150	10	SS304	400.410.7016	400.430.7016
225	200	8	SS304	400.410.1022	400.430.1022

PP-H Hand lever butterfly valve

Wafer type flange

JIS

<i>d</i> (mm)	<i>DN</i> (mm)	<i>PN</i> (bar)	<i>Stem</i>	<i>EPDM</i>	<i>FPM</i>
63	50	10	SS304	400.410.7263	400.430.7263
75	65	10	SS304	400.410.7275	400.430.7275
90	80	10	SS304	400.410.7290	400.430.7290
110	100	10	SS304	400.410.7211	400.430.7211
140	125	10	SS304	400.410.7214	400.430.7214
160	150	10	SS304	400.410.7216	400.430.7216
225	200	8	SS304	400.410.1222	400.430.1222

PP-H Hand lever butterfly valve

Wafer type flange

ANSI

<i>d</i> (In)	<i>DN</i> (mm)	<i>PN</i> (bar)	<i>Stem</i>	<i>EPDM</i>	<i>FPM</i>
2	50	10	SS304	400.010.7463	400.030.7463
2-1/2	65	10	SS304	400.010.7475	400.030.7475
3	80	10	SS304	400.010.7490	400.030.7490
4	100	10	SS304	400.010.7411	400.030.7411
5	125	10	SS304	400.010.7414	400.030.7414
6	150	10	SS304	400.010.7416	400.030.7416
8	200	8	SS304	400.010.1422	400.030.1422

Size data

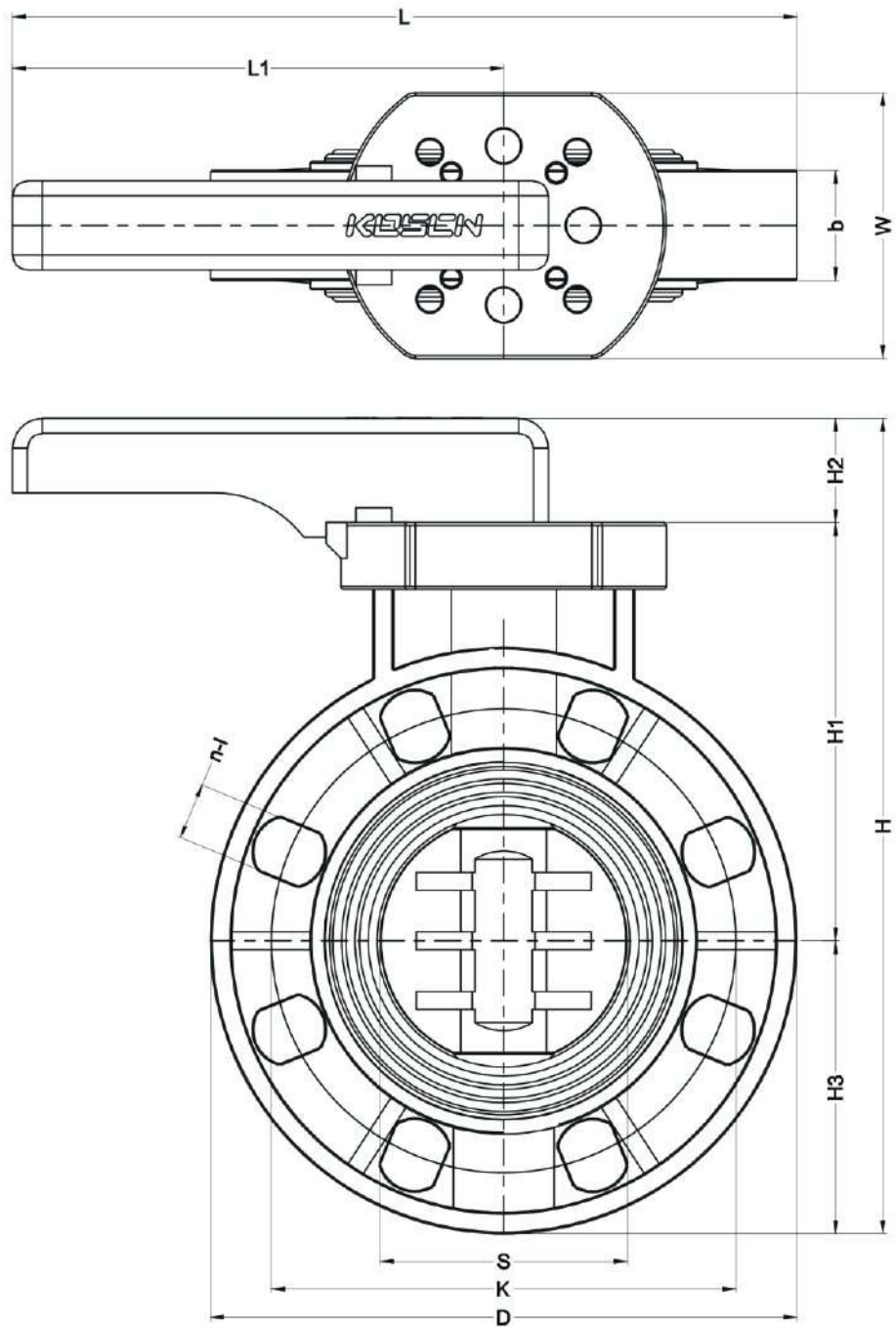

<i>d</i>	<i>DN</i>	<i>H</i>	<i>H1</i>	<i>H2</i>	<i>H3</i>	<i>D</i>	<i>K</i>	<i>S</i>	<i>n-DIN</i>	<i>n-JIS</i>	<i>n-ANSI</i>	<i>l</i>	<i>L</i>	<i>L1</i>	<i>W</i>	<i>b</i>
63	50	249	114	55	80	165	123	54	4	4	4	20	293	210	115	44
75	65	276	128	55	93	185	143	67	4	4	4	21	303	210	115	48
90	80	295	140	55	100	200	157	83	8	8	4	21	350	250	115	53
110	100	333	160	55	118	229	186	101	8	8	8	21	365	250	115	57
140	125	364	167	70	127	257	213	127	8	8	8	24	449	320	155	68
160	150	385	170	70	145	285	240	152	8	8	8	24	463	320	155	73
225	200	455	213	70	172	343	296	200	8	12	8	24	572	400	155	92



KV401 electric butterfly valve

Valve Body material of KV401 and the all basis data are basically the same as KV400 manual valve

Electric valves are coded extensions based on manual valves

Example: 400.010.1011 → 401.010.1011.XXX

Standard

KOSCN-xxN Normal On/Off Actuator

KOSCN-xxT Intelligent Modulating Actuator

KOSCN-xxB Intelligent Bus Actuator

Optional

KOSCN-xxC Intelligent On/Off Actuator

KOSCN-xxR Intelligent Wireless Actuator

KOSCN-xxD Intelligent Timer Actuator

Please consult KOSCN or agency for non-standard functions and parameters

TYPE	FUNCTION	V	d63	d75	d90	d110	d140	d160	d225
On/Off	Normal	DC 24V	...010	...010	...010	...010	...010	...010	...010
		AC 230V	...011	...011	...011	...011	...011	...011	...011
	High speed	DC 24V	...020	...020	...020	...020	...020	...020	...020
	Failsafe	DC 24V	...030	...030	...030	...030	...030	...030	...030
AC 230V		...031	...031	...031	...031	...031	...031	...031	
Intelligent Modulating	Normal	DC 24V	...110	...110	...110	...110	...110	...110	...110
		AC 95-265V	...111	...111	...111	...111	...111	...111	...111
	High speed	DC 24V	...120	...120	...120	...120	...120	...120	...120
	Failsafe	DC 24V	...130	...130	...130	...130	...130	...130	...130
AC 95-265V		...131	...131	...131	...131	...131	...131	...131	
Intelligent Bus	Normal	DC 24V	...210	...210	...210	...210	...210	...210	...210
		AC 95-265V	...211	...211	...211	...211	...211	...211	...211
	High speed	DC24V	...220	...220	...220	...220	...220	...220	...220
	Failsafe	DC 24V	...230	...230	...230	...230	...230	...230	...230
AC 95-265V		...231	...231	...231	...231	...231	...231	...231	

Overview of optional functions of electric actuator

KOSCN-xxN Normal On/Off Actuator

- * Matched valves: 2-way,3-way ball valve and butterfly valve
- * Rated voltage: DC12V,DC24V,AC24V/110V/230V
- * Control feedback mode: B3S,B3P,B3R,BD3S
- * High performance brushless motor,overheat/overload protection
- * It can be used up to 20,000 times
- * For AC series,it is forbidden to use two or more actuators in parallel

KOSCN-xxR Intelligent Wireless Actuator

- * Matched valves: 2-way,3-way ball valve and butterfly valve
- * Rated voltage: AC/DC95V-265V, AC/DC24V
- * Communication Mode: RF433/868/915MHZ,FSK,LORA,RF Ocean (single control)
- * Communication protocol: Compatible Modbus
- * Wireless Module: SX1278/SX1276/A7108
- * Communication distance: The maximum is 3Km
- * Achievable mode: 2 way/3 way
- * High performance brushless motor,overload or overheated protection of internal motor
- * It can be used up to 20,000 times

KOSCN-xxD Intelligent Timer Actuator

- * Matched valves: 2-way,3-way ball valve and butterfly valve
- * Rated voltage: AC/DC95V-265V, AC/DC24V
- * Timer mode: pulse mode , time mode
- * Loop mode : loop by days , loop by weeks
- * Adopted high-performance brushless motor, Overload protection of internal motor
- * It can be used up to 20,000 times.

KOSCN-xxC Intelligent On/Off Actuator

- * Matched valves: 2-way, 3-way ball valve and butterfly valve
- * Rated voltage: AC/DC95V-265V, AC/DC24V
- * Control feedback mode: BD3J,B3J,B33J,B43J(feedback synchronous with arrival)
- * Alarm output: A(Relay contact feedback)
- * Achievable mode: 2 way /3 way
- * High performance brushless motor,overload or overheated protection of internal motor
- * It can be used up to 20,000 times
- * Two or more actuators can be used in parallel

KOSCN-xxT Intelligent Modulating Actuator

- * Matched valves: 2-way,3-way ball valve and butterfly valve
- * Rated voltage: AC/DC95V-265V, AC/DC24V
- * Control signal: 4-20mA,0-20mA,0-10V,0-5V,1-5V,2-10V
- * Position feedback: 4-20mA
- * Position accuracy: 1%
- * Alarm output: A(Relay contact feedback)
- * High performance brushless motor,overload or overheated protection of internal motor
- * It can be used up to 20,000 times

KOSCN-xxB Intelligent Bus Actuator

- * Matched valves: 2-way,3-way ball valve and butterfly valve
- * Rated voltage:AC/DC95V-265V, AC/DC24V
- * Control feedback mode: RS485(Modbus), CANBus 2.0B/Mbus(customized)
- * Achievable mode: 2 way /3 way
- * High performance brushless motor,overload or overheated protection of internal motor
- * It can be used up to 20,000 times
- * Tow or more actuators can be used in parallel (RS485 could parallel maximum 32/64/256 actuators, while CANBus parallels 110 actuators)

Normal on/off model-wiring diagrams
B3S

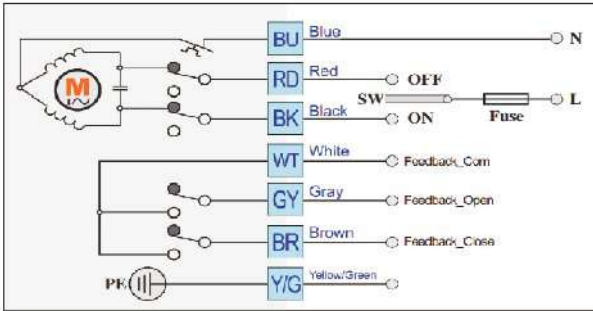

Normal on/off model-wiring diagrams
B3S- (DC series)

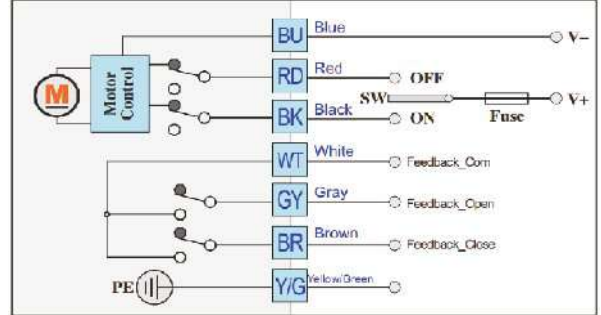

Normal on/off model-wiring diagrams
BD3S

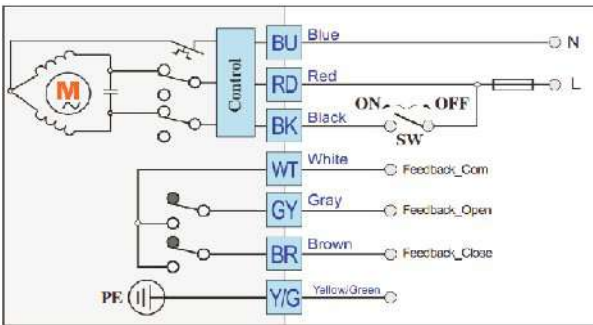

Normal on/off model-wiring diagrams
KT32S/BD3S (DC series)

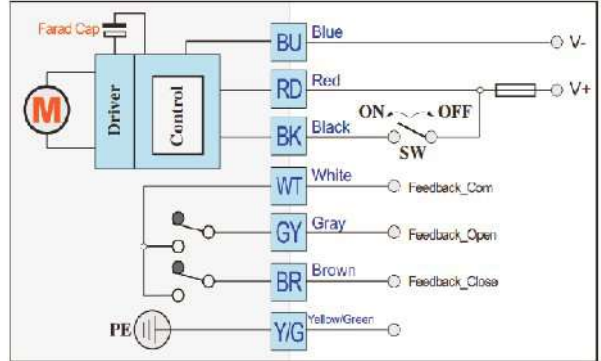

Intelligent modulating model-wiring diagrams
4-20mA / 0-20mA

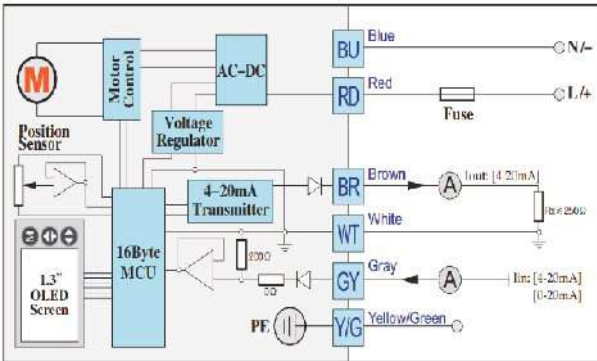

Intelligent modulating model-wiring diagrams
4-20mA-A / 0-20mA-A (Alarm)

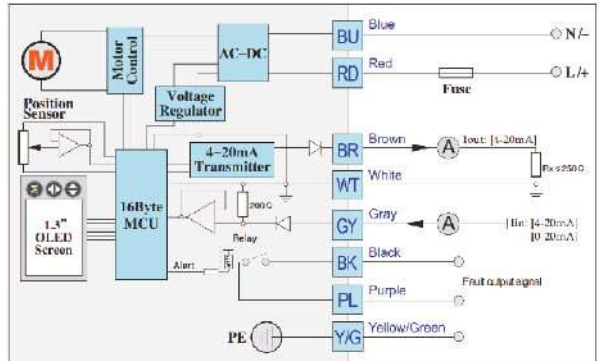

Intelligent Bus model -Wiring Diagram
RS485 / CANBUS (02B-KT)

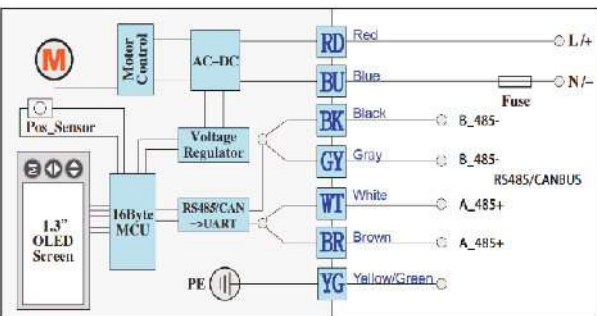

Interface

- Intelligent modulating model
- Intelligent Bus model interface



Size data

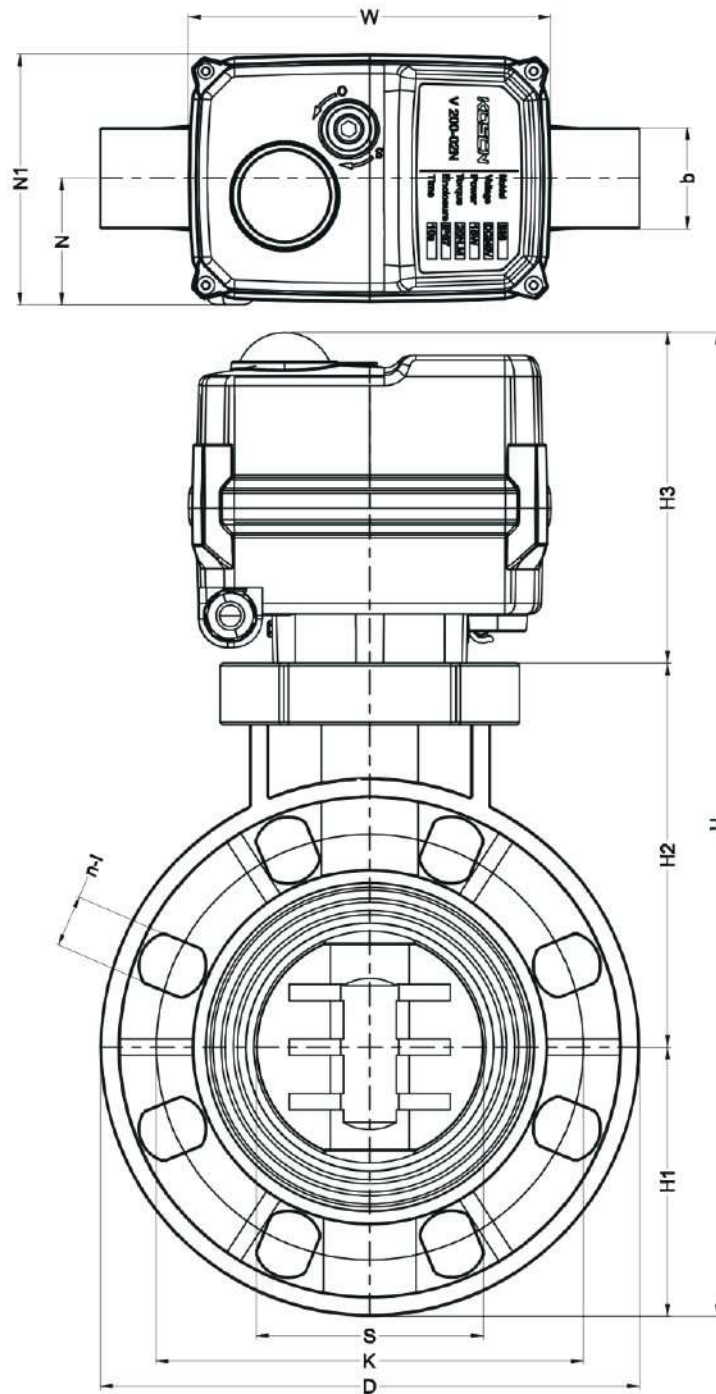

<i>d</i>	<i>DN</i>	<i>H</i>	<i>H1</i>	<i>H2</i>	<i>H3</i>	<i>D</i>	<i>K</i>	<i>S</i>	<i>n-DIN</i>	<i>n-JIS</i>	<i>n-ANSI</i>	<i>l</i>	<i>N</i>	<i>N1</i>	<i>W</i>	<i>b</i>
63	50	315	114	80	121	165	123	54	4	4	4	20	55	111	132	44
75	65	342	128	93	121	185	143	67	4	4	4	21	55	111	132	48
90	80	361	140	100	121	200	157	83	8	8	4	21	55	111	132	53
110	100	399	160	118	121	229	186	101	8	8	8	21	55	111	132	57
140	125	416	167	127	122	257	213	127	8	8	8	24	58	115	165	68
160	150	437	170	145	122	285	240	152	8	8	8	24	58	115	165	73
225	200	536	213	172	151	343	296	200	8	12	8	24	89	177	225	92



Kv402 Pneumatic butterfly valve

Valve Body material of KV402 and the all basis data are basically the same as KV400 manual valve

Pneumatic valves are coded extensions based on manual valves

Example: 400.010.1011 → 402.010.1011.XXX

Working pressure:

Input pressure of full plastic actuator: Pmax = 7 bar

Input pressure of aluminum body actuator: Pmax = 8 bar

Mechanical limit:

Full plastic actuator is standard, Aluminum body actuators are optional, please contact with KOSCN or agency for selection and ordering

Position feedback:

All actuators can be extended with position feedback modules,

Feedback signal voltage : AC/DC 12-265V

Mounting brackets:

Fully plastic cover plate mounting parts

ISO 5211 connection standard

Material	Control	Type	d63	d75	d90	d110	d140	d160	d225
Full plastic	NC	Standard	...010	...010	...010	...010	...010	...010	...010
		Micro switch
	NO	Standard	...020	...020	...020	...020	...020	...020	...020
		Micro switch
	DA	Standard	...030	...030	...030	...030	...030	...030	...030
		Micro switch
Aluminum	NC	Standard	...110	...110	...110	...110	...110	...110	...110
		Micro switch
	NO	Standard	...120	...120	...120	...120	...120	...120	...120
		Micro switch
	DA	Standard	...130	...130	...130	...130	...130	...130	...130
		Micro switch

Driving work instructions

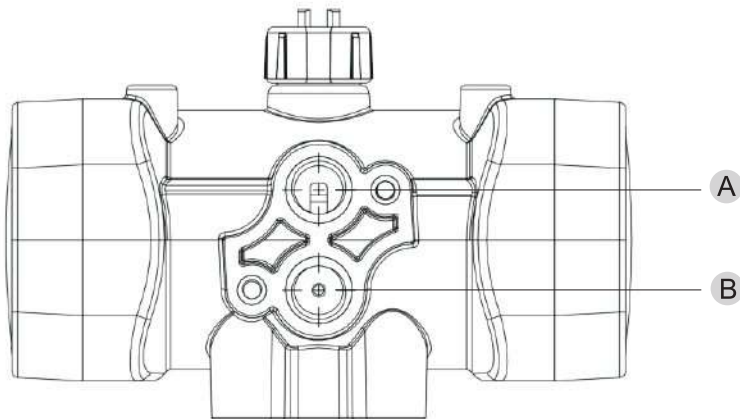

Air source interface size: A air inlet G1/4 or 1/8 threaded
 B air inlet G1/4 or 1/8 threaded

NC: control pressure connects air inlet B, valves open

NO: control pressure connects air inlet B, valves close

DA: control pressure connects air inlet A, valves close; control pressure connects air inlet B, valves open

NC/NO pilot-operated valve: with 3/2 solenoid valve

DA pilot-operated valve: with 5/2 solenoid valve

Note:

The driving pressure of all actuators cannot be higher than the upper limit to ensure safe use and achieve optimal functions. If the control pressure exceeds the limits, a malfunction may occur. In this case, a new actuator configuration is required.

Size data

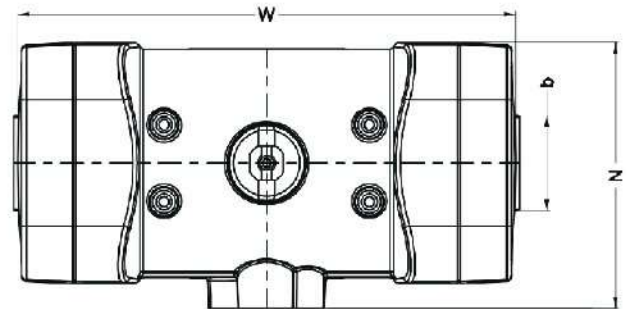
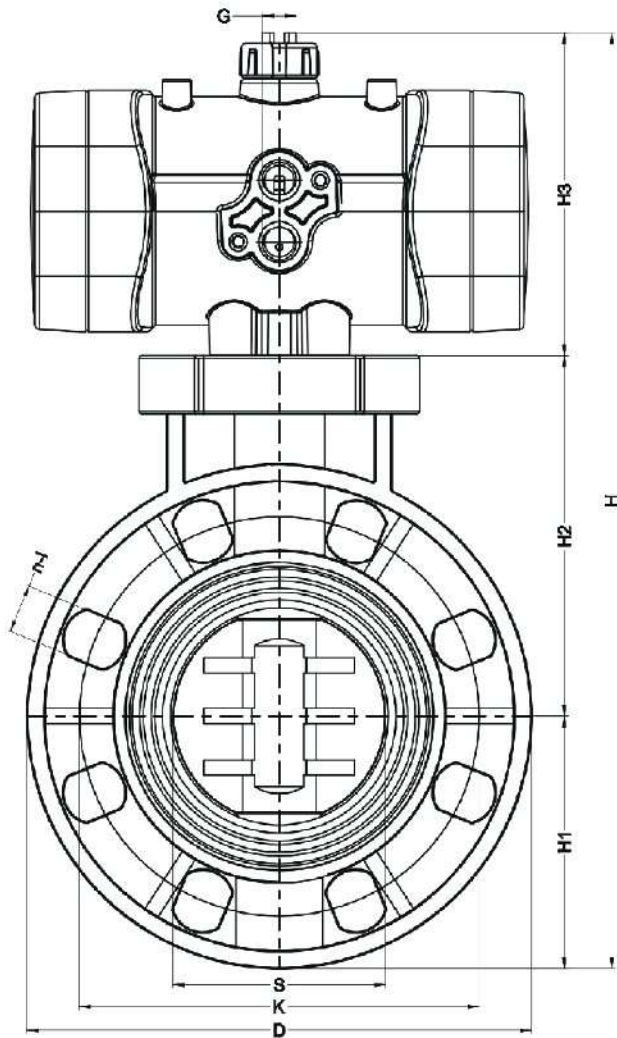

DN	H		H3		N		W	
	AI	PPGF	AI	PPGF	AI	PPGF	AI	PPGF
SR								
50	295	312	101	118	81	90	162	176
65	338	351	117	130	95	104	207	192
80	357	370	117	130	95	104	207	192
100	407	*	129	*	106	*	238	*
125	466	*	172	*	137	*	328	*
150	487	*	172	*	137	*	328	*
200	590	*	205	*	164	*	432	*
DA								
50	295	312	101	118	81	90	162	176
65	322	339	101	118	81	90	162	176
80	341	370	101	130	81	104	162	192
100	395	408	117	130	95	104	207	192
125	436	*	142	*	123	*	272	*
150	457	*	142	*	123	*	272	*
200	557	*	172	*	137	*	328	*

d	DN	H1	H2	D	K	S	n	n	n	l	b
63	50	114	80	165	123	54	4	4	4	20	44
75	65	128	93	185	143	67	4	4	4	21	48
90	80	140	100	200	157	83	8	8	4	21	53
110	100	160	118	229	186	101	8	8	8	21	57
140	125	167	127	257	213	127	8	8	8	24	68
160	150	170	145	285	240	152	8	8	8	24	73
225	200	213	172	343	296	200	8	12	8	24	92

* No data, can't configure temporarily

Plastic limit switch MA620



- Easy installation and maintenance, cylinder top base directly installed.
- Unlimited caliber.
- 0~90° or 0~180° stroke, adjustable.
- Using imported mechanical micro switch, long life, high reliability.
- Standard configuration of silver alloy contacts, other silver and gold materials can be selected.
- Optional reply and proximity switches. Optional PNP or NPN mode.
- It has explosion-proof configuration

Power voltage	24V/DC , Single loop current 2.5A*2 230V/DC , Single loop current 2.5A*2
Power consumption	24V/DC , 10W*2 230V/DC , 15W*2
Electrical connections	M12 Waterproof Conn
The input signal	Switch quantity
Protection grade	IP 65
Shell material	PA6 , PC
Environment temperature	-20℃ ~ +80℃

Optional: metal limit switch MA620 , please consult KOSCN or local agent for details.



**ontact**
customer center
www.koscn.cn



KOSCN