



Paddlewheel Flow Meter  
FP-AS Series  
FP-AS510



With Patented

**AxleSense**

Technology

# FP-AS510

Patented AxleSense Paddlewheel Flow Meter



Premium pipe fitting

Flexible Device installment:  
Vertical/Horizontal

High Brightness LED

Situational Backlight:  
Instant Visual Feedback

Modular 3 piece design : Easier maintenance

Axlesense technology:  
High accuracy measurement

Bidirectional Flow Tracking

# Fluid Measurement Made Simple with Paddle Wheel Flowmeters

For industries that rely on precise fluid measurement such as water management, chemical processing, and agriculture, paddle wheel flowmeters have been a trusted solution for decades. Known for their practicality and reliability, paddle wheel deliver accurate results without the complexity or high costs of advanced systems.

## Challenges of Traditional Designs

While effective, traditional paddle wheel flowmeters face issues like paddle wear, installation sensitivities, and limited detection capabilities, which can affect long-term reliability, accuracy and efficiency.

## Working Principle

A paddle wheel inside the pipe spins as fluid flows past it. Sensors track the rotation speed of the paddle wheel and translate this motion into accurate readings. It's a practical and proven method for flow measurement.

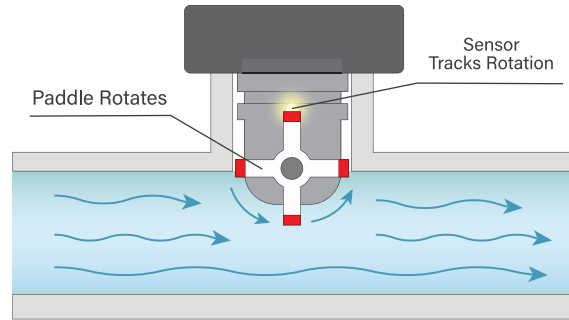

# Reinventing Paddle Wheel Flowmeters: Precision Perfected with LORRIC's AxleSense



AxleSense technology revolutionizes signal measurement, significantly increasing signal output frequency for more accurate flow measurement.

## Others vs LORRIC

Conventional paddle wheels have 4 blades ; signals are generated only when **magnets on the blades** pass the sensor.

generate one signal **per blade pass (90°)**

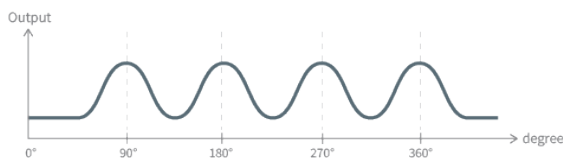
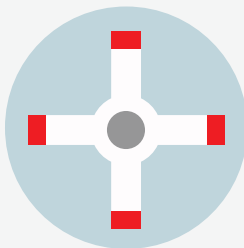

**Standard Four-Blade Flow Meters Output**  
One Signal per 90 Degrees Rotation  
Generally 1 to 2 Output per Revolution (max 4)

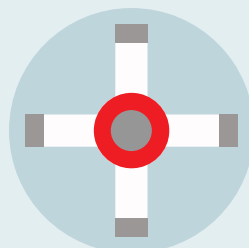

AxleSense Technology with **magnet on the axle**; signals are generated by measuring magnetic axle rotation.

generate one signal **every 3°**

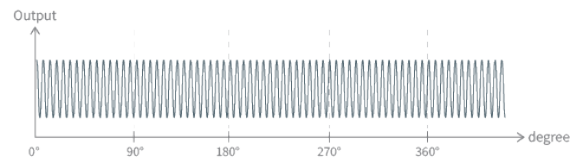

**LORRIC AxleSense Flow Meters Output**  
One Signal Every 3 Degrees  
120 Outputs per Revolution

# Bi-Directional Flow Detection

Accurately measure flow direction and calculate positive, negative, and net flow.

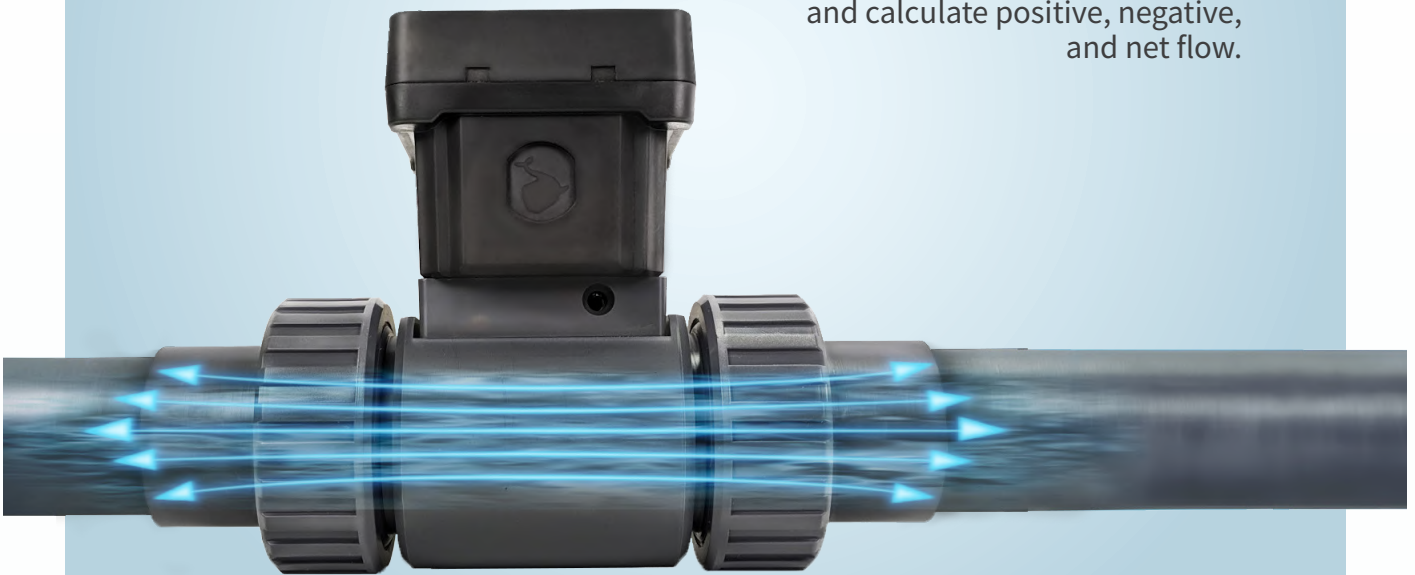

AxleSense's patented technology enables bidirectional flow detection by measuring paddlewheel rotation direction, overcoming the limitations of other brands that use Hall effect sensors, which can detect rotation but not direction.

In the FP-AS510, this innovative feature provides complete real-time insights of fluid flow and flow direction information, with positive, negative, and net flow calculations — all in one device. completed with a 14-day history of daily accumulations, optimizing operations and enhancing on-site management efficiency.



Traditional Paddle Wheel Flowmeter

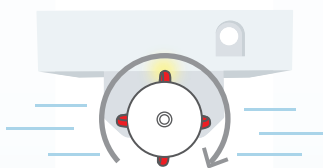

Detects flow by sensing the magnet on the paddles, without recognizing flow direction.

LORRIC's AxleSense

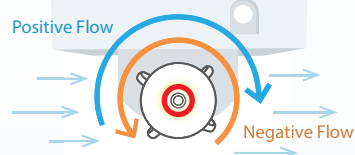

Detects both flow and direction by sensing the magnet rotation on the axle

## Wider Detection Range

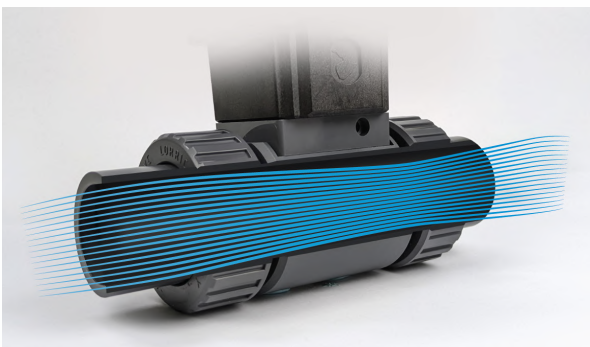
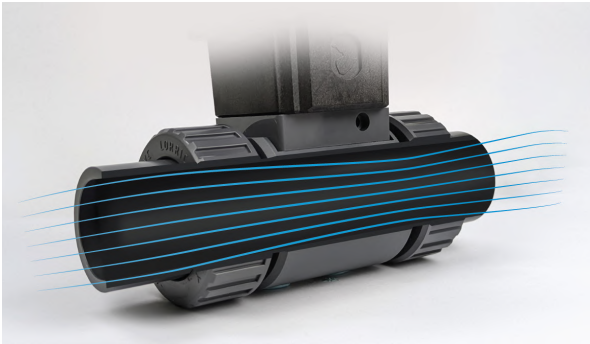

Accurate detection on both low and high flow rates

Traditional paddlewheel flow meters often have significant errors or cannot detect flow at low flow rates in the fluid inside the pipe. Upgrade your flow measurement capabilities with LORRIC's AxleSense technology! No more worries about inaccurate readings or missed low flow rates. Our advanced innovation ensures enhanced accuracy and a broader measurement range, spanning from 0.15 m/s to 10 m/s- double that of competing brands.

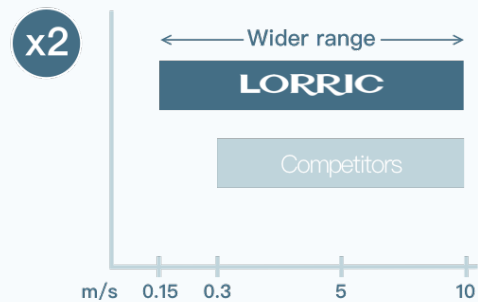

## Historical Data at Your Fingertips



Gain a deeper understanding of your system's performance with our flowmeter's 14-day daily flow log feature. Once enabled, you can check the daily flow data from the past 14 days at any given time.

\*Note:  
This function must be manually enabled, and data before activation is unavailable. Daily flow data automatically updates to cover the past 14 days.

# Real Time Smart Paddle Detection

Unexpected flow disruptions can impact your entire operation, but LORRIC's Real-Time Smart Detection keeps you one step ahead. By continuously monitoring the paddlewheel's condition, including magnet strength, wear, and damage, it ensures accurate readings and sends immediate alerts when issues arise. This minimizes downtime, prevents costly errors, and boosts operational efficiency. Ideal for critical industries, it seamlessly integrates with factory systems in Industry 4.0 environments, enabling smarter and more efficient management.

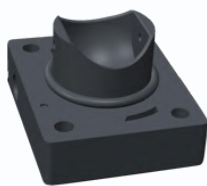
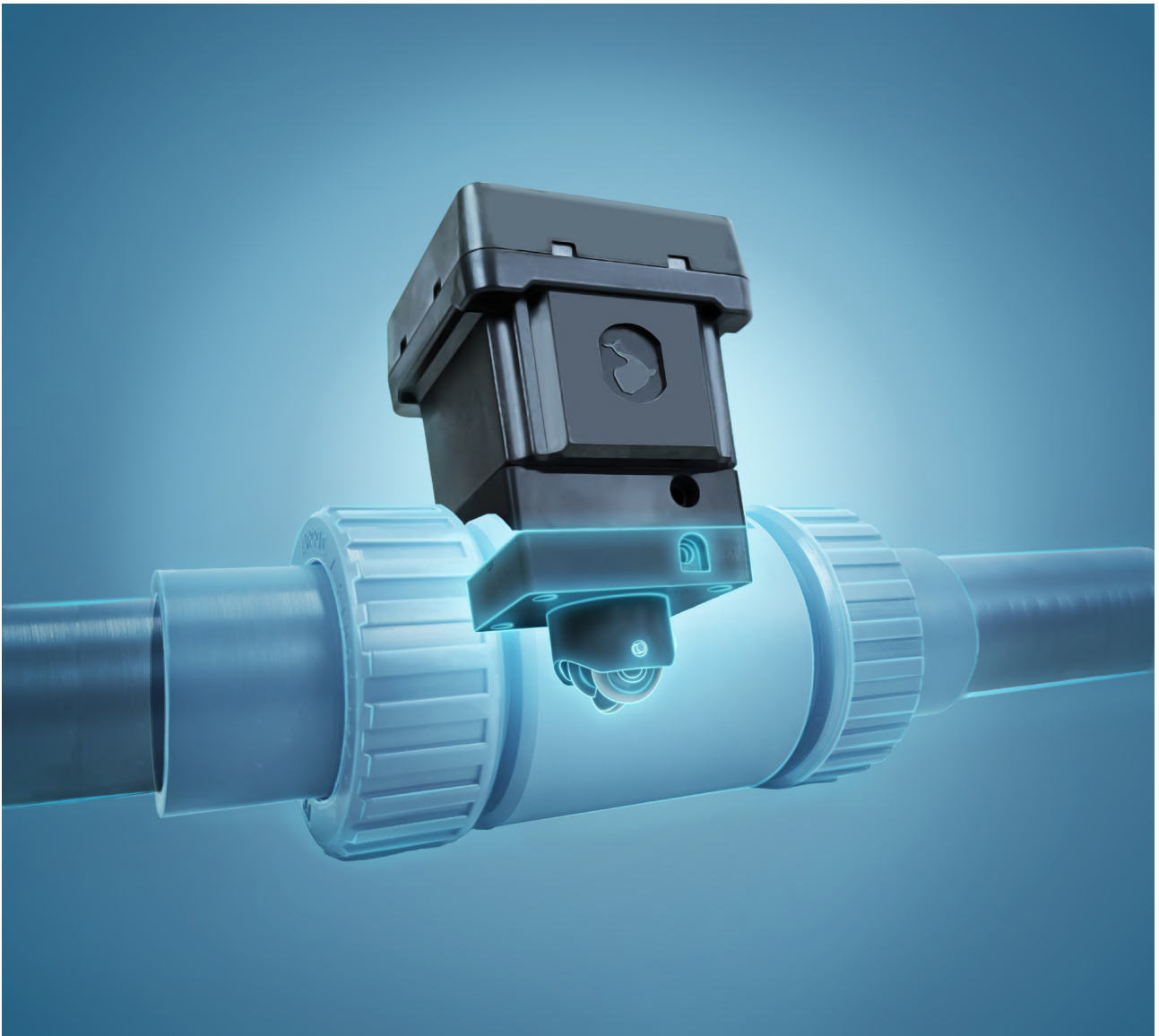

More details on  
AxleSense online Manual:  
Parameter List > H System  
> H05

\*Usage Note: The abnormality warning function helps on-site staff quickly identify equipment issues. However, it may be affected by environmental factors, nearby equipment, or magnetic interference, reducing its effectiveness. Do not rely on this feature as your sole source for critical or safety-related alerts. For detailed troubleshooting or further assistance, please contact LORRIC for additional support

# Instant Visual Feedback

Dual LCD/LED screens for easy traffic and equipment status monitoring

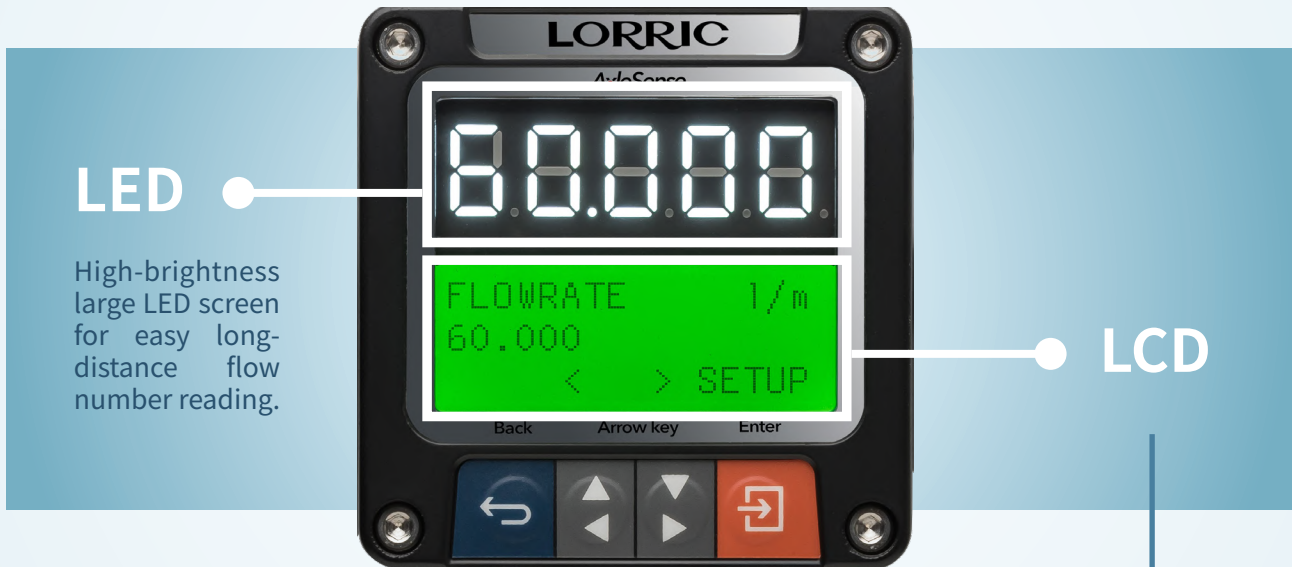

LCD screen backlight with three-color warning light signal for visual monitoring of flow meter's normal and abnormal conditions.

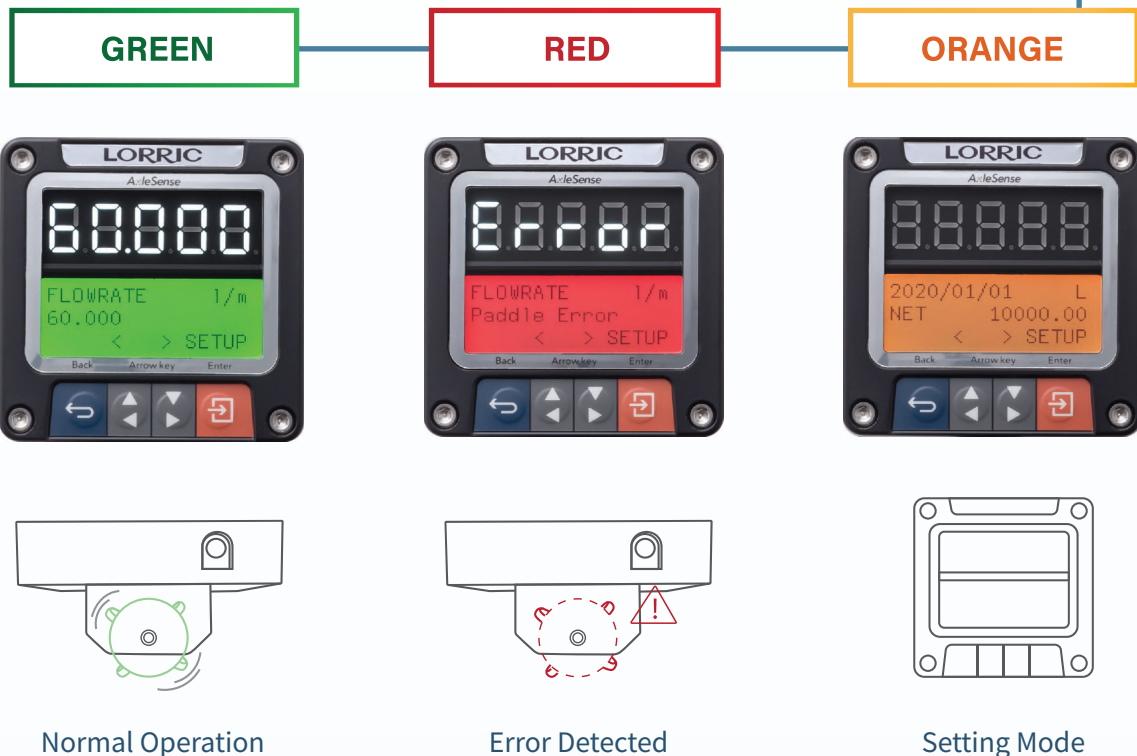

# Flexible Installation Options

Designed for both vertical and horizontal mounting, making installation simple and versatile.

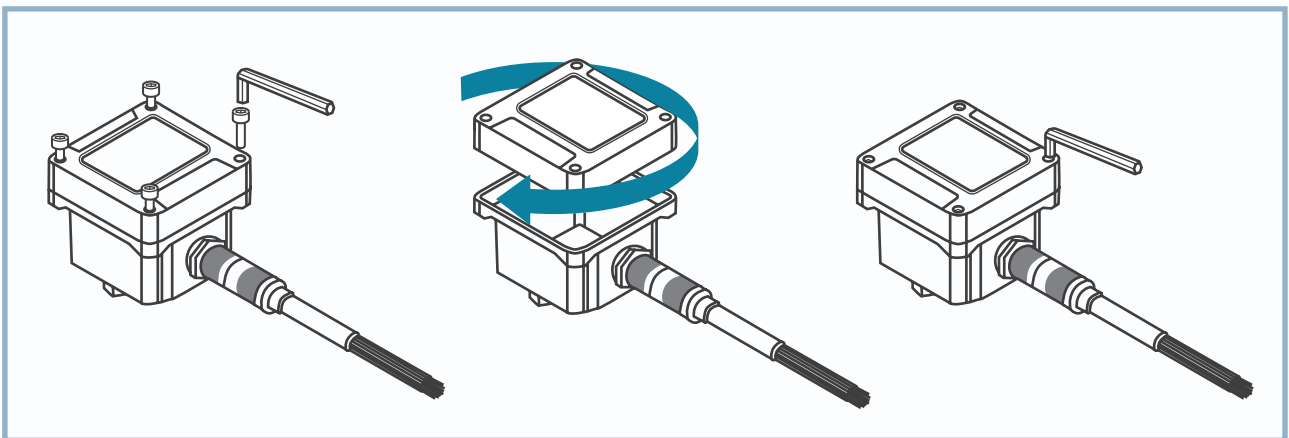

1. Unscrew the display panel to release it.

2. Rotate the screen to your desired orientation

3. Reattach and tighten the screws securely to lock the screen in place



## Easy Maintenance with LORRIC's Modular 3-Piece Design

LORRIC's paddlewheel flowmeter features an innovative 3-piece design that simplifies maintenance and reduces costs. The system consists of three main components: the main unit, paddlewheel base, and pipe fitting. This modular design means you don't need to replace the entire system when a part wears out—just swap the affected component, saving both time and money on re-piping.



## Universal Compatibility for FP-AS Series



LORRIC offers two versatile main unit models, FP-AS510 and FP-AS310, which are compatible with the same paddlewheel base and pipe fitting. This compatibility ensures easy maintenance and flexibility, helping you optimize your operations without worrying about costly part replacements.

With LORRIC, enjoy seamless maintenance, minimized downtime, and cost-efficient flow monitoring for the long haul, all in one.

# Why Pipe Fitting Quality Matters in Flow Measurement

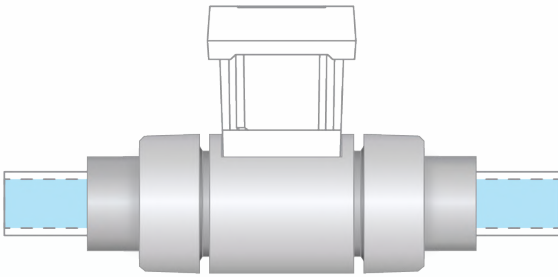

Pipe fittings are more than just connectors — they play a critical role in maintaining accurate flow measurement. Poorly manufactured fittings, especially those with uneven surfaces or imperfections, can disrupt the fluid flow, leading to turbulence, pressure drops, and inaccurate readings. Over time, these issues can compromise system efficiency and increase maintenance costs.

## LORRIC's Premium Pipe Fittings: Engineered for Precision and Durability

### Other Brands

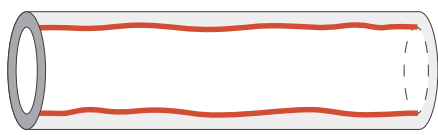

Wavy, inconsistent pipe fitting wall surface

Traditional plastic injection molding methods often produce fittings with uneven surfaces and inconsistent pipe walls, leading to unstable fluid flow and inaccurate readings. These issues, such as shrinkage, flash, and weak welds, can reduce the lifespan of fittings and compromise performance.

### LORRIC

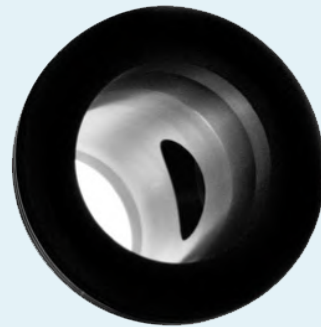

Flawless, smooth inner pipe fitting wall surface

At LORRIC, we've redefined pipe fitting quality with our premium manufacturing process. Instead of relying on conventional plastic injection molding, our fittings are crafted from extruded rod material. This method ensures a flawless, smooth inner surface that promotes stable fluid flow and enhances measurement precision.

When you choose LORRIC, you're not just selecting a fitting — you're investing in better performance, reduced downtime, and peace of mind. Our commitment to precision delivers the quality your system deserves.

## Versatile Pipe Fittings for Every Industry: Choose the Right Material for Your Application

LORRIC's paddle wheel flowmeters are designed to provide flexibility and durability with pipe fittings made from a variety of materials, each carefully selected to meet the specific needs of different industries. Whether you're handling water, chemicals, or high-pressure systems, we have the right solution for you.

**PPH (Polypropylene Homopolymer)**

Suited for corrosive chemicals and industrial fluids.  
Temperature range: 0°C to 90°C.

**UPVC (Unplasticized Polyvinyl Chloride)**

Ideal for water, mild chemicals, and non-corrosive fluids.  
Temperature range: 0°C to 50°C.

**PVDF (Polyvinylidene Fluoride)**

Perfect for aggressive chemicals, acids, and high-purity applications.  
Temperature range: -20°C to 140°C.

**Stainless Steel**

Ideal for high-pressure systems, hot fluids, and abrasive liquids.  
Temperature range: -20°C to 140°C.

# Specifications

Installation method	in-line (Pipe segment)
T-connector adapter	UPVC/PPH / PVDF (Made to order) / 316L Stainless Steel
Paddle material	PVDF or PPH with embedded magnet + ceramic bearing and shaft
Applicable fluid	Various liquids, impurities (<1%)
Applicable fluid maximum dynamic viscosity	300cSt *
Fluid in pipes temperature **	UPVC 0-45°C (32~122°F) / PPH : 0-80°C/PVDF: 0-100°C / ss316L : 0-100°C
Device working environment temperature	-10~60°C (14~140°F)
Flow velocity range	± 0.3~10m/s can extend to ± 0.15m 10m/s ***
Language	English, Traditional Chinese, Simplified Chinese (Others customizable)
Unit	Metric: Liter, cubic meters, meters / Time: second, minute, hour, day / Imperial: foot, Cubic foot, Uk gallon, US gallon
Display	Double screen display: Large 5-Digit LED, 16x3 3-Color Backlight LCD display
Response time	0.5s 1s
Display resolution	Maximum resolution 0.0001 (finest)
Measurement accuracy	+2.5% RD ****
Linearity	±0.5% FS (>0.3m/s)
Reproducibility	± 0.4 %
Power supply	DC 12V to 36V 100mA
Power I/O connector	M12 8-pin connector
Input/Output	Analog output with self-powered 16-bit 4-20mA / Modbus RTU RS485/ Two-wire optocoupler switch signal (with 2 meters long signal line)
Consumption current	<200mA@12V when starting up and working stably (not included in the communication current)
Protection circuit	Power reverse connection protection, Power surge protection
Waterproof level	IP66 *****
Transient data	Instantaneous flow velocity / Flow volume
Cumulative data	Cumulative flow (Positive flow / Negative flow / Net flow) daily cumulative flow in the past 14 days (date function activated after installing date battery)
Display digits	LED 5 Digits (4 digits when negative value) / LCD 10 Digits (Not including sign and decimal point)
Operation button	4 Key touch buttons
Calendar function battery	CR2032

\*This machine is calibrated with normal temperature water before leaving the factory. Fluids with different viscosity than water will cause inaccurate calibration values and may also change the minimum and maximum flow rates.



\*\* The working temperature of each material is for reference only. Please select based on design experience for actual selection.

\*\*\* Minimum flow rate values vary slightly due to flow field factors of individual models.

\*\*\*\* The measurement accuracy is based on the statistical results of the laboratory tests with room temperature 25 degrees C and clean water. Errors may occur due to the customer's usage environment.

\*\*\*\*\* The IP of IP66 is the abbreviation of Ingress Protection. The IP level is the protection level of the electrical equipment shell against foreign matter intrusion. The format of the IP level is IPXX, where XX is two Arabic numerals, and the first marked number indicates contact protection, and foreign object protection level, used to indicate dust resistance, the second marked number indicates the waterproof protection level, the larger the number, the better the protection level. The first 6 of IP66 means: completely prevent dust from entering; the second 6 means: no harm caused by high-pressure water splashing.

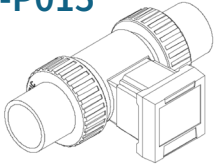
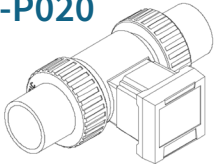
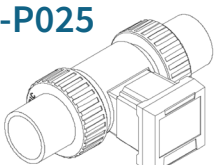
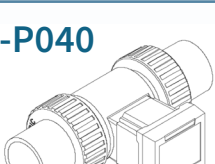
## Explore FP-AS510 Configurations: Size, Flowrate, and Pipe Fitting Options

	Applicable Diameter	Flow Range	Fitting Material Options
<b>FP-P015</b> 	DN 15 (mm)	1.8-120.6 LPM	<ul style="list-style-type: none"> <li>• UPVC</li> <li>• PPH</li> <li>• PVDF</li> <li>• Stainless Steel (316L)</li> </ul>
	1/2" NPS	0.47-28.4 gpm	
<b>FP-P020</b> 	DN 20 (mm)	2.8-188.5 LPM	<ul style="list-style-type: none"> <li>• UPVC</li> <li>• PPH</li> <li>• PVDF</li> <li>• Stainless Steel (316L)</li> </ul>
	3/4" NPS	0.83-49.86 gpm	
<b>FP-P025</b> 	DN 25 (mm)	4.4-294.5 LPM	<ul style="list-style-type: none"> <li>• UPVC</li> <li>• PPH</li> <li>• PVDF</li> <li>• Stainless Steel (316L)</li> </ul>
	1" NPS	1.35-80.81 gpm	
<b>FP-P032</b> 	DN 32 (mm)	6.8-452.9 LPM	<ul style="list-style-type: none"> <li>• UPVC</li> <li>• PPH</li> <li>• PVDF</li> <li>• Stainless Steel (316L)</li> </ul>
	1¼" NPS	2.33-139.86 gpm	
<b>FP-P040</b> 	DN 40 (mm)	11.3-754.0 LPM	<ul style="list-style-type: none"> <li>• UPVC</li> <li>• PPH</li> <li>• PVDF</li> <li>• Stainless Steel (316L)</li> </ul>
	1½" NPS	3.17-190.36 gpm	
<b>FP-P050</b> 	DN 50 (mm)	18.4-1225.7 LPM	<ul style="list-style-type: none"> <li>• UPVC</li> <li>• PPH</li> <li>• PVDF</li> <li>• Stainless Steel (316L)</li> </ul>
	2" NPS	5.23-313.77 gpm	
<b>FP-P065</b> 	DN 65 (mm)	32.7-2179.0 LPM	<ul style="list-style-type: none"> <li>• UPVC</li> <li>• PPH</li> <li>• PVDF</li> </ul>
	2½" NPS	8.77-526.29 gpm	

# Size | UPVC | PPH | PVDF

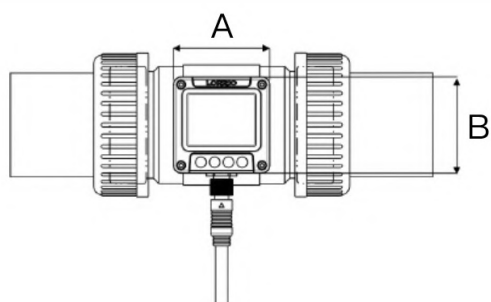

Unit: mm

Device size	
A	B
63	63

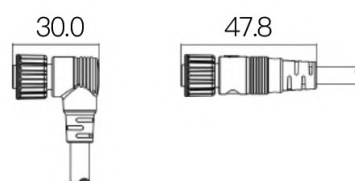
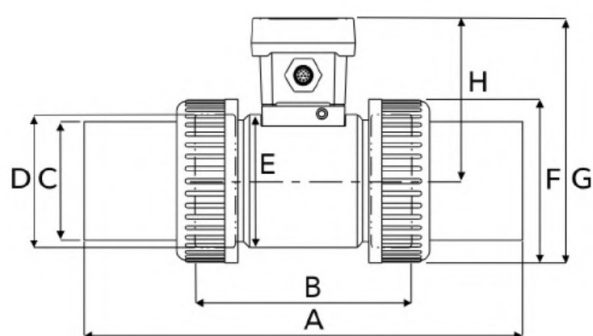

Unit: mm

Plastic pipe – union diameter size								
	A	B	C	D	E	F	G	H
1/2"	164	100	27.6	36	62.3	46.2	115.7	86.2
3/4"	168	100	32.6	41.9	62.3	50.5	115.7	85.7
1"	168	100	40.6	50	62.3	60	115.7	85.7
1 1/4"	210	114	50.2	59.6	65	75.6	127	89.2
1 1/2"	218	120	56	65.7	70	83	134	92.5
2"	269.5	133.3	72	81	81	99.7	148.8	99

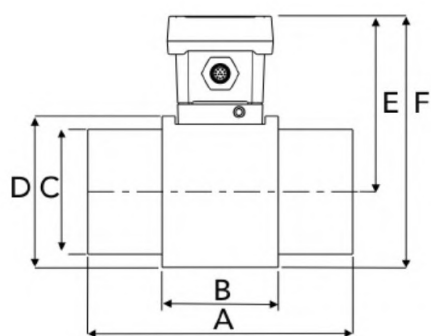

Unit: mm

Plastic pipe – spigot pipe diameter size						
	A	B	C	D	E	F
2 1/2"	160	70	76	92	106.5	152.5

# Size | Stainless Steel

## Metal Female Thread

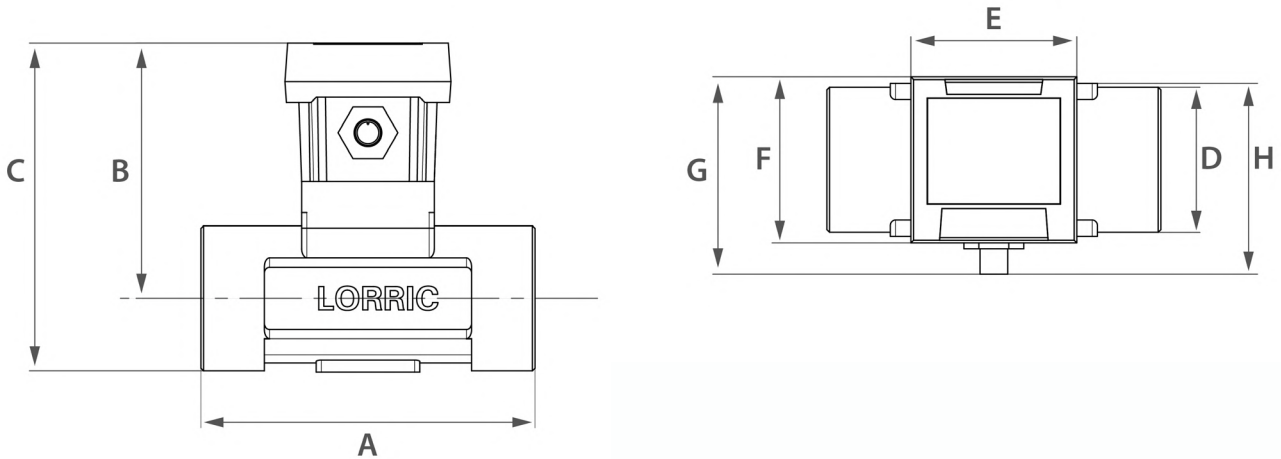

Stainless steel - Female Thread								
	A	B	C	D	E	F	G	H
1/2"	120	89.37	103.4	27	64.1	64.1	64.1	76.15
3/4"	120	89.5	106.91	-	64.1	64.1	64.1	76.15
1"	120	89.41	111.16	42	64.1	64.1	-	76.15
1 1/4"	119	95.2	120.7	51	64.1	64.1	51	76.15
1 1/2"	129	98.55	126.55	56	64.1	64.1	56	76.15
2"	148.5	104.98	137.98	65	64.1	64.1	76.15	78.12

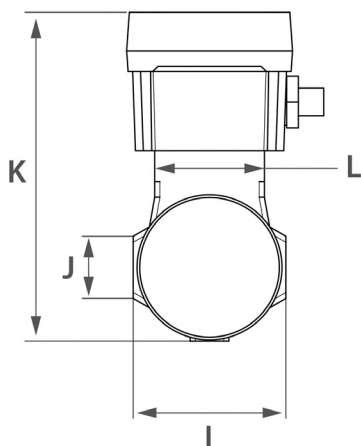

Stainless steel - Female Thread				
	I	J	K	L
1/2"	95.41	-	95.41	42.4
3/4"	42.4	-	106.91	42.4
1"	-	-	111.16	42.4
1 1/4"	54	20	121.2	42.4
1 1/2"	59	24	127.05	42.4
2"	68	30	137.98	42.4

# Size | Stainless Steel

## DN 25 1" Metal Male Thread

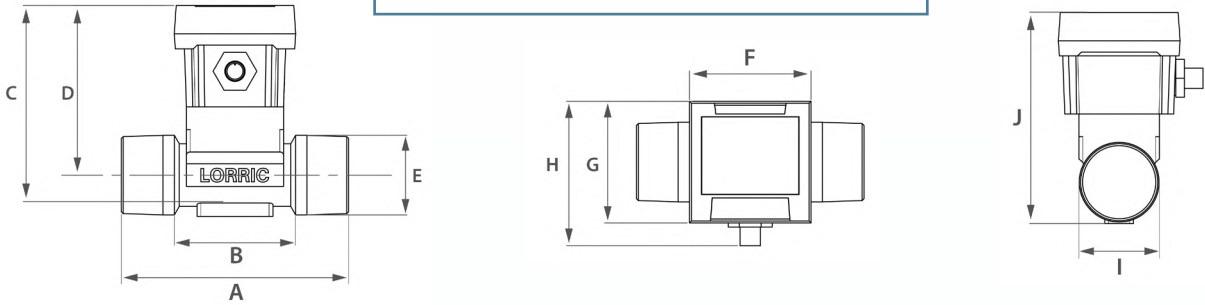

DN-25 (1") Stainless steel - Male Thread

	A	B	C	D	E	F	G	H	I	J
1/2"	120	58.8	111.16	89.41	33	64.1	64.1	76.15	42.4	111.16

## DN 20 3/4" Metal Male Thread

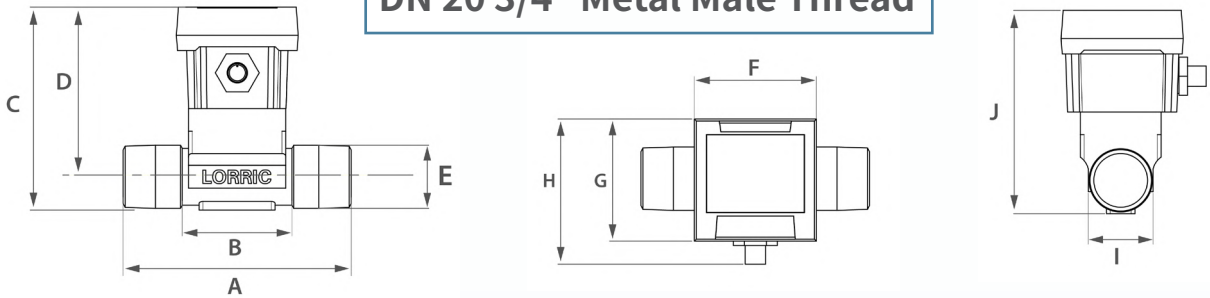

DN-20 (3/4") Stainless steel - Male Thread

	A	B	C	D	E	F	G	H	I	J
3/4"	120	57.69	106.09	89.4	30	64.1	64.1	76.15	42.4	106.09

## DN 15 1/2" Metal Male Thread

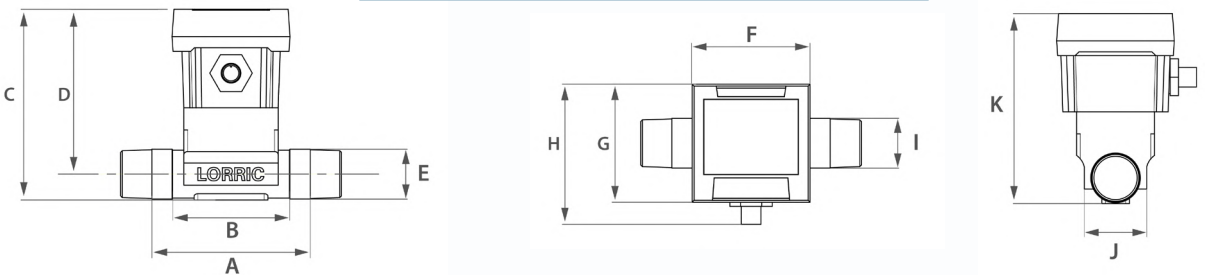

DN-15 (1/2") Stainless steel - Male Thread

	A	B	C	D	E	F	G	H	I	J
1"	120	63.42	103.41	89.41	26	64.1	64.1	76.15	34	103.41



# How to Order (Union Fitting)

The whole set of paddle wheel flowmeter contains: Device, Paddle set, T-connector.  
Please check the material and size of the T-connector and paddle set before placing order.

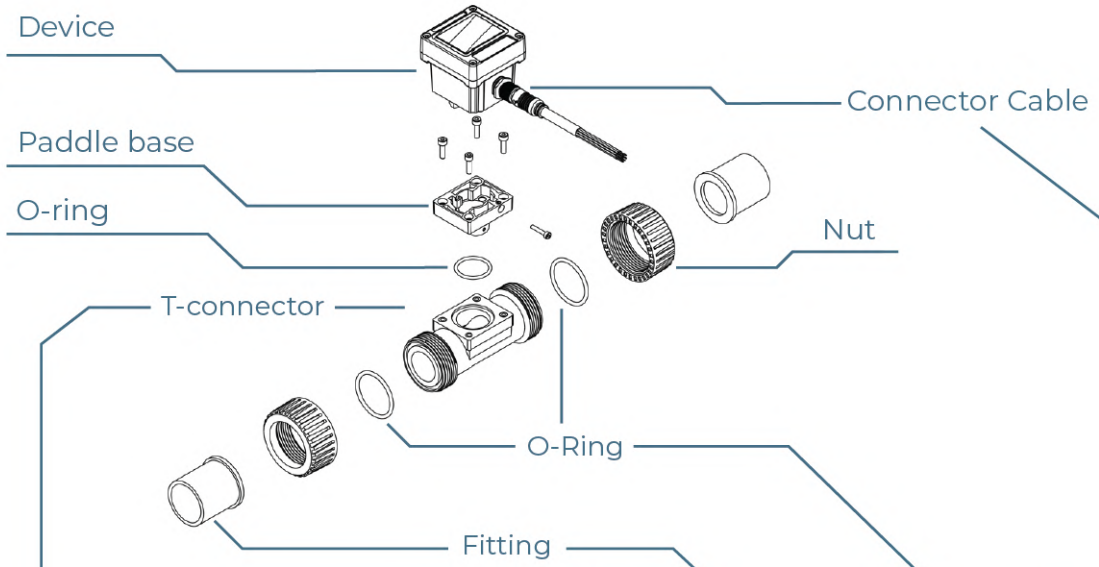

**Please Choose:**

<b>1</b>	<b>T-connector</b>	<b>2</b>	<b>Fitting Spec</b>	<b>3</b>	<b>O-Ring Material</b>	<b>4</b>	<b>Cable head</b>
	Select pipe size:	Select pipe material:	Select T-connector fitting:	Select fitting spec:	Select material:	Select cable head type:	

Order Code Example:	<b>FP-P065</b>	<b>C</b>	<b>U</b>	<b>A</b>	<b>V</b>	<b>R</b>
---------------------	----------------	----------	----------	----------	----------	----------

Code:

FP-P015	1/2" Pipe
FP-P020	3/4" Pipe
FP-P025	1" Pipe
FP-P032	1-1/4" Pipe
FP-P040	1-1/2" Pipe
FP-P050	2" Pipe

Code: **C**

U-PVC

Code: **P**

PPH

Code: **F**

PVDF

Code: **S**

Stainless Steel (316L)

Code: **U**

Union + fitting

For Spigot & Flange fitting, Please refer to next page

(For Stainless Steel T-connector):

Code: **T**

Thread

Code: (For U-PVC T-connector):

<b>T</b>	Taiwan CNS
<b>A</b>	ANSI/ASTM
<b>N</b>	GB
<b>J</b>	JIS
<b>E</b>	DIN
<b>F</b>	BSPT Female Thread
<b>M</b>	BSPT Male Thread
<b>R</b>	NPT Female Thread
<b>Q</b>	NPT Male Thread

(For PPH / PVDF T-connector):

<b>6</b>	Insertion welding fitting (Default): ISO 15494 (PPH) ISO 10931 (PVDF)
<b>5</b>	Butt welding fitting (Made to order): ISO 15494 SDR11 (PPH) ISO 10931 SDR21 (PVDF)

(For Stainless Steel T-connector):

<b>F</b>	BSPT Female Thread
<b>M</b>	BSPT Male Thread

Code:

<b>E</b>	EPDM
<b>V</b>	VITON
<b>A</b>	FEPM

Code: **S**

Straight

Code: **R**

90° angle

\* The common specifications are listed above, please contact our sales for delivery and inventory.



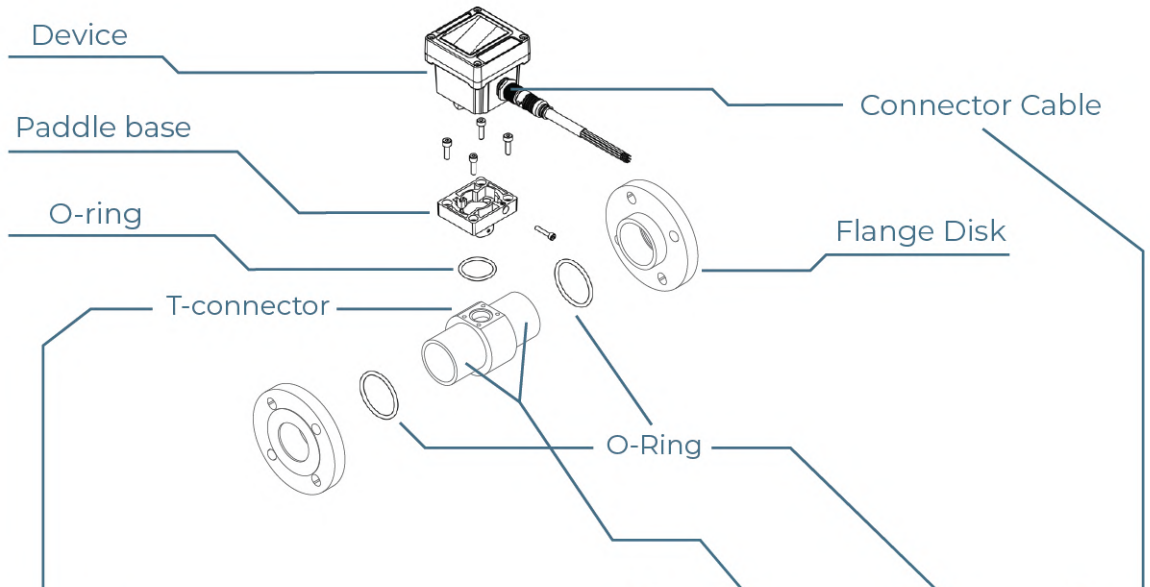



# How to Order (Spigot/Flange Fitting)



Please Choose:

<b>1</b>	<b>T-connector</b>	<b>2</b>	<b>Fitting Spec</b>	<b>3</b>	<b>O-Ring Material</b>	<b>4</b>	<b>Cable head</b>
	Select pipe size:	Select pipe material:	Select T-connector fitting type:	Select fitting spec:	Select material:	Select cable head type:	

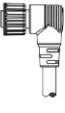
Order Code Example: **FP-P065** **C** **S** **A** **V** **R**

Code: <input type="checkbox"/> FP-P065 2-1/2" Pipe	Code: <input checked="" type="checkbox"/> <b>C</b> U-PVC  <input type="checkbox"/> <b>P</b> PPH  <input type="checkbox"/> <b>F</b> PVDF	Code: <input type="checkbox"/> <b>S</b> Spigot fitting 	Code: ( For U-PVC T-connector ) : <input checked="" type="checkbox"/> <b>T</b> Taiwan CNS <input checked="" type="checkbox"/> <b>A</b> ANSI/ASTM <input type="checkbox"/> <b>N</b> GB <input type="checkbox"/> <b>J</b> JIS <input type="checkbox"/> <b>E</b> DIN ( For PPH / PVDF T-connector ) : <input type="checkbox"/> Insertion welding fitting (Default): <input checked="" type="checkbox"/> <b>6</b> ISO 15494 (PPH) ISO 10931 (PVDF) <input type="checkbox"/> Butt welding fitting (Made to order): <input checked="" type="checkbox"/> <b>5</b> ISO 15494 SDR11 (PPH) ISO 10931 SDR21 (PVDF)	Code: <input type="checkbox"/> <b>E</b> EPDM <input type="checkbox"/> <b>V</b> VITON <input type="checkbox"/> <b>A</b> FEPM	Code: <input type="checkbox"/> <b>S</b> Straight  <input type="checkbox"/> <b>R</b> 90° angle 
Flange fitting (Available by custom order only)	<input type="checkbox"/> FP-P050 2" Pipe <input type="checkbox"/> FP-P065 2-1/2" Pipe Please contact our sales for other pipe sizes	<input type="checkbox"/> <b>U-PVC</b> <input type="checkbox"/> <b>Stainless Steel (316L)</b> <input type="checkbox"/> <b>F</b> 	Code: ( For Flange ) : <input type="checkbox"/> <b>K</b> JIS 10K TS		

\* The common specifications are listed above, please contact our sales for delivery and inventory.

# LORRIC AxleSense Paddlewheel Flow Meter Series: AS510 vs. AS310

**FP-AS510**



**FP-AS310**



Complex conditions,  
require more features

**Suitable Scenarios**

OEM customers,  
large-scale installations,  
price-sensitive applications



**Double screen design**  
LED 5 Digits LCD 10 Digits

**Screen Display**



**Single screen design**  
LCD 10 Digits

Positive flow  
negative flow  
net flow volume

**Total Flow**

Positive flow only

**One version**

For Analog output 4-20mA,  
Modbus RTU RS485, 2-wire  
photoelectric switch signal  
(compatible with NPN/PNP)

**Model Types**

**Two version**

FP-AS310R for rs485  
FP-AS310A for 4-20mA and  
Switch Signal (NPN)

Flow speed 0.15~10m/s

**Measurement Range**

Flow measurement  
above 0.3 m/s



**M12 8-pin**  
DC 12V to 36V 100mA

**Power Modes**



**Quick-release 6-pin**  
DC24V 100mA

# Specification Comparison

	FP-AS510	FP-AS310R/FP-AS310A
Suitable Scenarios	Complex conditions, require more features	OEM customers, large-scale installations, price-sensitive applications
Device Material	PC + GF (glass fiber)	PC + GF (glass fiber)
Power Demand	DC 12V to 36V 100mA	DC24V 100mA
Fluid Temperature	0~50°C (32~122°F)	0~50°C (32~122°F)
Working Environment Temperature	-10~60°C (14~140°F)	-10~60°C (14~140°F)
Models Types	One version for Analog output 16bit 4-20mA, Modbus RTU RS485, 2-wire photoelectric switch signal (compatible with NPN/PNP)	Two versions FP-AS310R for RS485, FP-AS310A for 4-20mA, 2-wire photoelectric switch signal (compatible with NPN/PNP)
4-20mA Resolution	16-bit	10-bit
Power I/O Connector	M12 8-pin	Quick-release 6-pin
Data Accumulation Display	Cumulative flow: positive flow, negative flow, and net flow volume. Includes a 14-day historical flow record with timestamps.(past 14 days daily totalizer)	Cumulative flow: Positive Flow (Display only positive flow, direction selectable)
Transient Data	Instantaneous flow rate, instantaneous flow velocity	Instantaneous flow rate
Display Digits	LED 5 Digits LCD Maximum 9 digits	LCD Maximum 9 digits
Calendar Function Battery	CR2032 (For past 14 days totalizer only)	No battery
Bi-directional Flow Detection	Yes, show both positive and negative flow	No, flow direction can be changed but only positive will display
Volume and Time unit	Volume unit: L, m3, US Gallon, Imperial Gallon, ft3. Time Unit: seconds, minutes, hours, days.	Flow Units: m3, L, US gallons, ft3 Time Units: minutes, hours
Flow Velocity Unit	Unit of flow speed, default m/s. Metric: m/s Imperial: ft/s	N/A
Extension Mode	Set Low Flow Extension, Maximum Measurement Flow Range: 0.15~10m/s.	Set Low Flow Extension, Maximum Measurement Flow Range: 0.3~10m/s.
Pulse Width	0.5 ms (millisecond), 1ms, or 10ms. The default is 0.5ms.	1ms, or 10ms. The default is 1ms.
RS485 Baud	The Modbus communication baud rate can be set when the device is turned off to 9600, 19200, 38400, or 57600. The default setting is off.	The Modbus communication baud rate can be set when the device is turned off to 9600, 19200, or 38400. The default setting is off.
Iout Def. (Iout Definition)	4 options of the output data of Analog signal: off, flowrate, velocity and total.	The output data of the analog signal is the instantaneous flow rate.
Iout Range	2 options of analog signals: 4-20mA, 0-20mA Default is 4-20mA.	Only one analog signals: 4-20mA



**LORRIC**

**United Benefit Corp**

8F, No.3, Lane 83, Sec. 1, Guangfu Rd.  
Sanchong Dist. New Taipei City

TEL: +886-2-8511-2135  
FAX: +886-2-8511-2097  
E-mail: sales@lorric.com

[www.lorric.com](http://www.lorric.com)



FP-AS510 Website



FP-AS510  
Instruction Manual